

# UWB Module MS01SF1

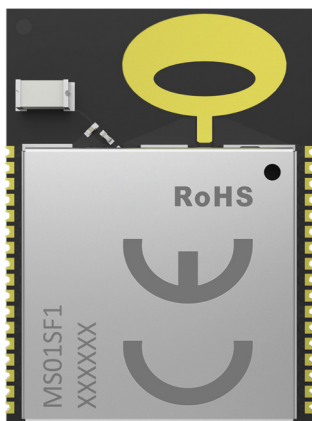

Datasheet  
V 1.0.0



## Version Note

Version	Details	Contributor(s)	Date	Notes
1.0.0	First edit	Michelle, Leo	2024.06.06	

## Part Number

Model	Hardware Code
MS01SF17	7Y33AI

Click the icon to view and download the latest product documents electronically.  
[https://en.minewsemi.com/file/MS01SF1-DW3120\\_Datasheet\\_K\\_EN.pdf](https://en.minewsemi.com/file/MS01SF1-DW3120_Datasheet_K_EN.pdf)



# MS01SF1-nRF52833+DW3120

## Ranging Transmission, UWB Dual Channel Available, Bluetooth 5.2+UWB Module with Acceleration Sensor

MS01SF1 is a UWB high-precision wireless distance measurement module, using Nordic high-end nRF52833 Bluetooth chip as the main control, through Bluetooth to Decawave high-precision distance measurement chip DW3120 parameter settings and control the DW3120 to carry out the distance measurement operation, to obtain the corresponding results, and then to the cell phone or other host devices, and with acceleration sensor, can meet the needs of industrial intelligence and other scenarios. nRF52833 open 23 IO ports can be configured as UART, SPI, I2C, smart city, public inspection and justice. The nRF52833 can meet the needs of industrial intelligence, safety production, warehousing and logistics, smart city, public prosecutors and law enforcement agencies, etc. The nRF52833 is open to 23 IO ports, which can be configured as UART, SPI, I2C, PWM and other interfaces, which is convenient for the secondary development of the customer.

### FEATURES



Bluetooth 5.2 + UWB



Positioning accuracy 10-30cm



Maximum 6.8Mbps Transmission Rate



UWB dual channel available



With USB port



With accelerometer

### KEY PARAMETER

MS01SF1			
Chip Model	Nordic nRF52833+Decawave DW3120	Antenna	Chip+PCB
Module Size	26.12×19.13×3.2mm	GPIO	BLE:23 + UWB:4
Flash	512KB	RAM	128KB
BLE Receiving Sensitivity	-96dBm	BLE Transmission Power	-40 ~ +8dBm
BLE Current(TX)	0dBm- 4.6mA	BLE Current(RX)	4.8mA
UWB Receiving Sensitivity	-94dBm	UWB Current(RX)	55mA
UWB Current(TX)	140mA		

### APPLICATION



Smart Buildings



Consumer Electronics



Smart Healthcare



Security Equipment



Automotive Devices



Smart Agriculture



# INDEX

1.Electrical Specification .....	05
2.Block Diagram .....	05
3.Pin Description .....	05
4.Pin Definition .....	06
5.Mechanical Drawing .....	07
6.Module Interface Schematic .....	07
7.PCB Layout .....	09
8.Reflow and Soldering .....	09
9.Package Information .....	10
10.Storage Conditions .....	11
11.Handling Conditions .....	11
12.Quality .....	11
13.Copyright Statement .....	12
14.Related Documents .....	12

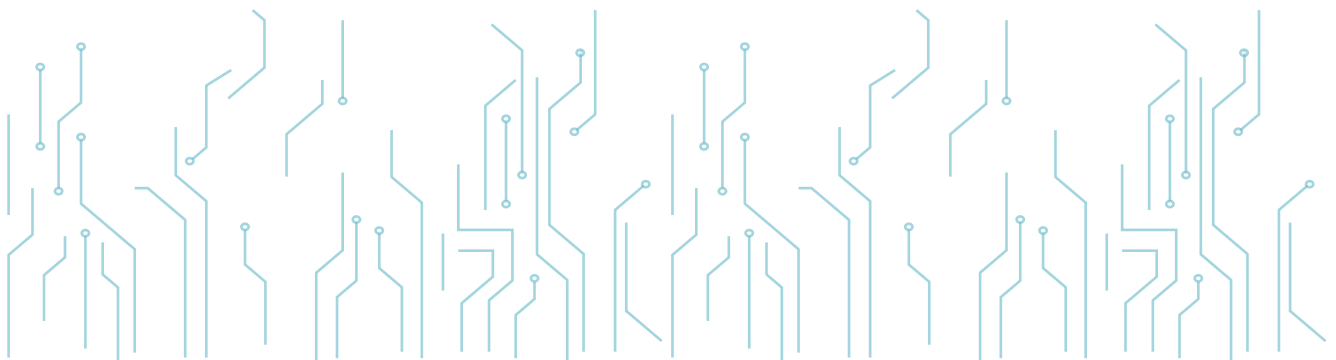

# 1 ELECTRICAL SPECIFICATION

Parameter	Minimum value	Classical values (math.)	Maximum values (of measure)	unit	Notes
Operating temperature	-30		+85	°C	
Storage temperature	-40		+85	°C	
Supply Voltage VCC	2.8		3.6	V	
Sleep Current		0.05		mA	deep sleep
TX Current		140		mA	Channel 5
Bluetooth TX Current		14		mA	
RX Current		55		mA	
Frequency range	6240	6489.6	6739.2	MHz	Channel 5 Center Frequency
		7987.2		MHz	Channel 9 Center Frequency
Measuring distance	30		80	m	Transmission rate: 6.8 Mbps

# 2 BLOCK DIAGRAM

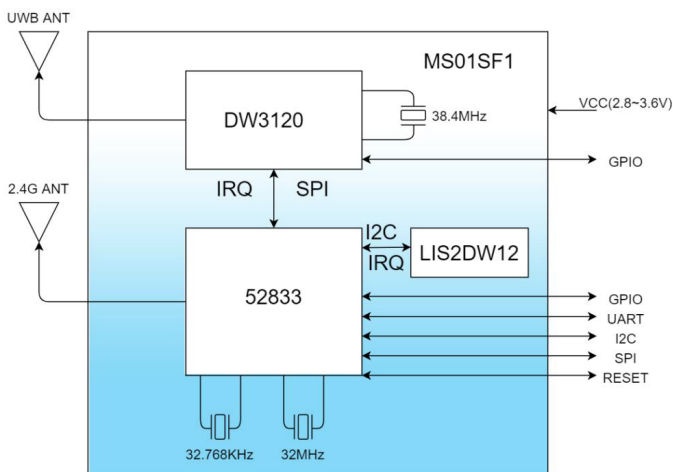

# 3 PIN DESCRIPTION

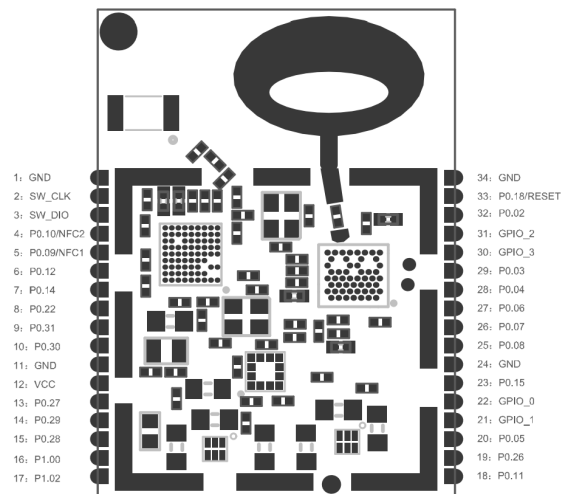

# 4 PIN DEFINITION

Pin Number	Pin Symbol	Pin Type
1	GND	GND
2	SWDCLK	nRF52833 burn-in clock pins
3	SWDIO	nRF52833 burn data pins
4	P0.10	nRF52833 General Purpose IO Port
5	P0.09	nRF52833 General Purpose IO Port
6	P0.12	nRF52833 General Purpose IO Port
7	P0.14	nRF52833 General Purpose IO Port
8	P0.22	nRF52833 General Purpose IO Port
9	P0.31	nRF52833 general-purpose IO port/ADC pinout
10	P0.30	nRF52833 general-purpose IO port/ADC pinout
11	GND	GND
12	VCC	Power supply pin: 2.8V~3.6V
13	P0.27	nRF52833 General Purpose IO Port
14	P0.29	nRF52833 General Purpose IO Port
15	P0.28	nRF52833 General Purpose IO Port
16	P1.00	nRF52833 General Purpose IO Port
17	P1.02	nRF52833 General Purpose IO Port
18	P0.11	nRF52833 General Purpose IO Port
19	P0.26	nRF52833 General Purpose IO Port
20	P0.05	nRF52833 General Purpose IO Port
21	GPIO_1	General purpose IO ports on the DW3120
22	GPIO_0	General purpose IO ports on the DW3120
23	P0.15	nRF52833 General Purpose IO Port
24	GND	GND
25	P0.08	nRF52833 General Purpose IO Port
26	P0.07	nRF52833 General Purpose IO Port
27	P0.06	nRF52833 General Purpose IO Port
28	P0.04	nRF52833 General Purpose IO Port
29	P0.03	nRF52833 General Purpose IO Port
30	GPIO_3	General purpose IO ports on the DW3120
31	GPIO_2	General purpose IO ports on the DW3120
32	P0.02	nRF52833 General Purpose IO Port
33	P0.18	nRF52833 general purpose IO port/reset pin
34	GND	GND

# 5 MECHANICAL DRAWING

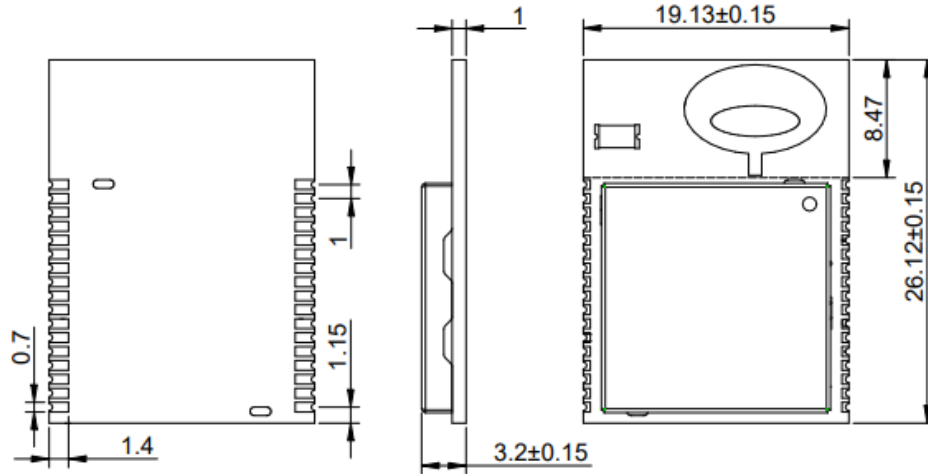

- ⚠ Default unit: mm Default tolerance: ±0.15
- ⚠ Notice: The recommended pad size is 1.8\*0.8mm with a pad extension of 0.5mm

# 6 ELECTRICAL SCHEMATIC

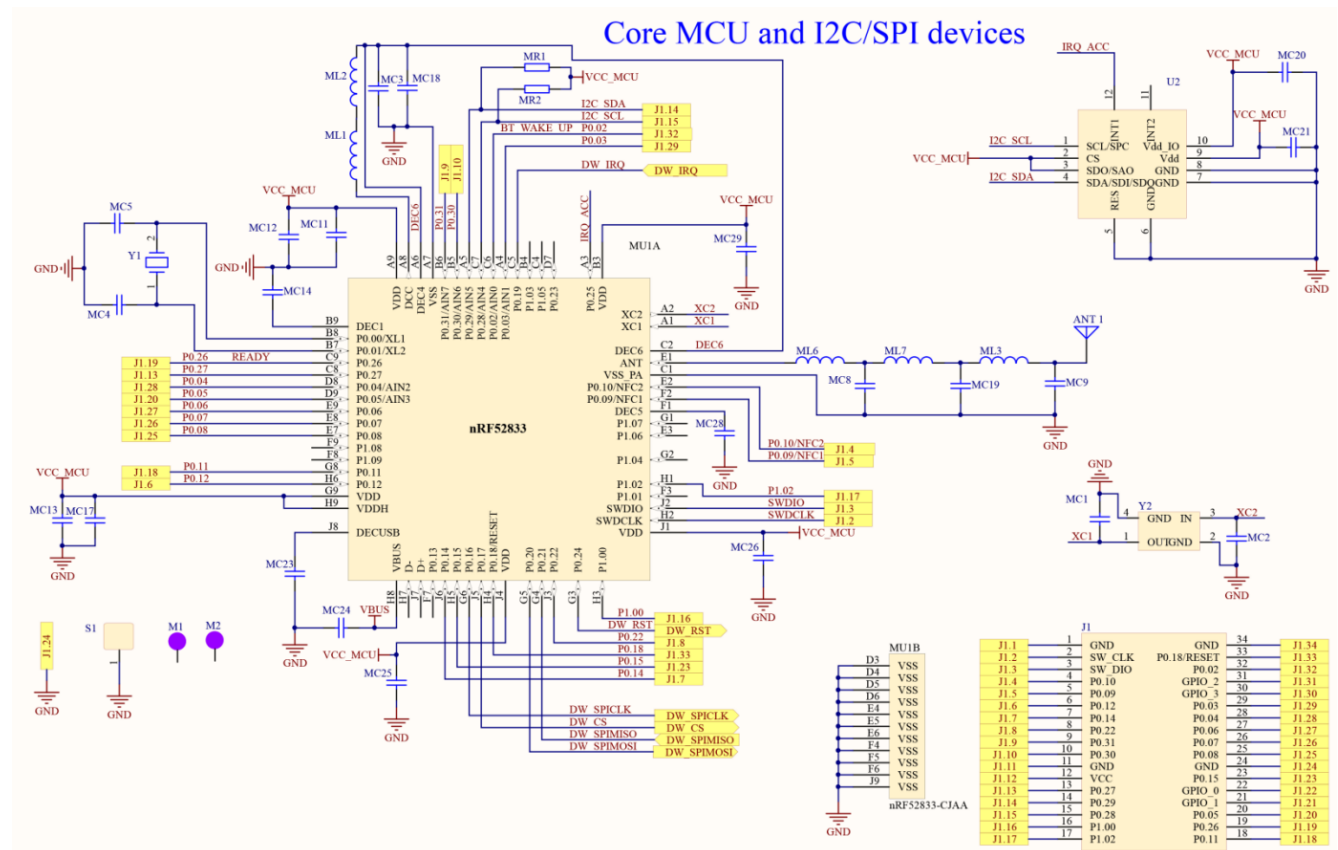

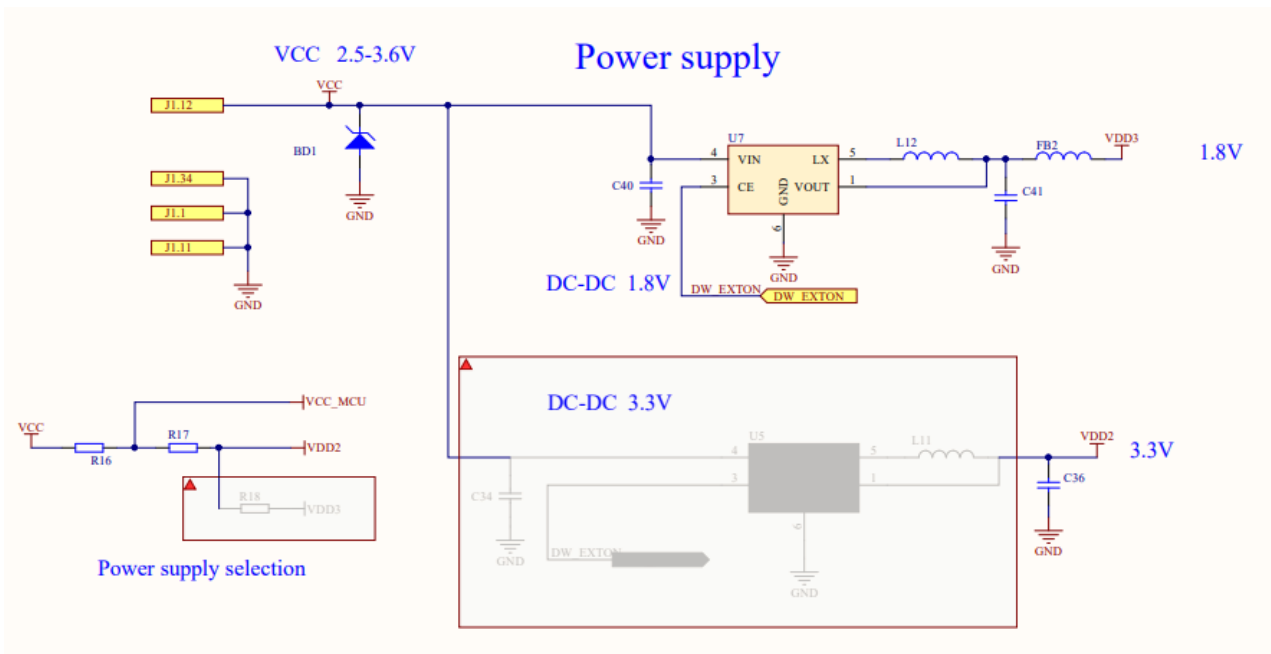
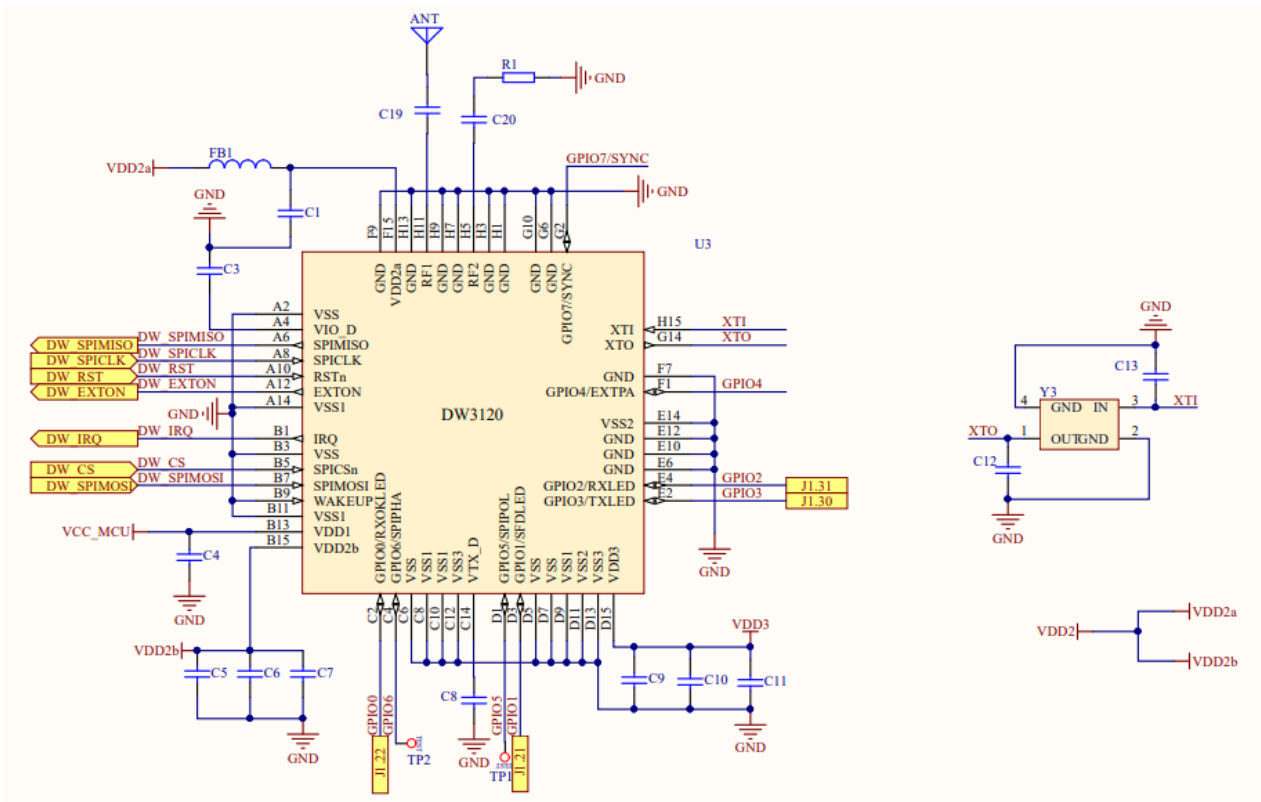

Notice: Before placing an order, please confirm the specific configuration required with the salesperson.



## 7 PCB LAYOUT

The proximity of the UWB module antenna to metal and other non-RF transparent materials needs to be carefully considered when soldering the UWB module to the top of the PCB. The following is a recommended placement scheme for UWB modules, as shown in the figure. For optimal RF performance of the module, the application board grounding copper cladding should cover as much area as possible, except for the area labeled "Keep-out Area". There should be no metal on either side, above or below the module antenna. (e.g. do not place batteries under the antenna). For both placement options shown, the application board has no metal in the module antenna area. For the diagram on the left, the antenna extends out of the application board from the edge, leaving the module antenna area in free space. In the diagram on the right, the module antenna is not in free space, but the sides and underside of the application board where the module antenna is located are netted without PCB copper skins. In addition, the grounding area of the application board affects the radiation effect diagram of the module antenna. (It is recommended that no metal exists within a minimum distance of  $d=10\text{mm}$  on either side of the module antenna).

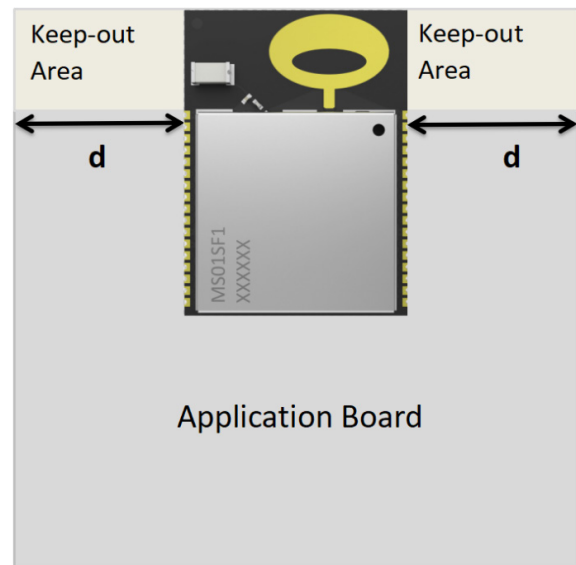
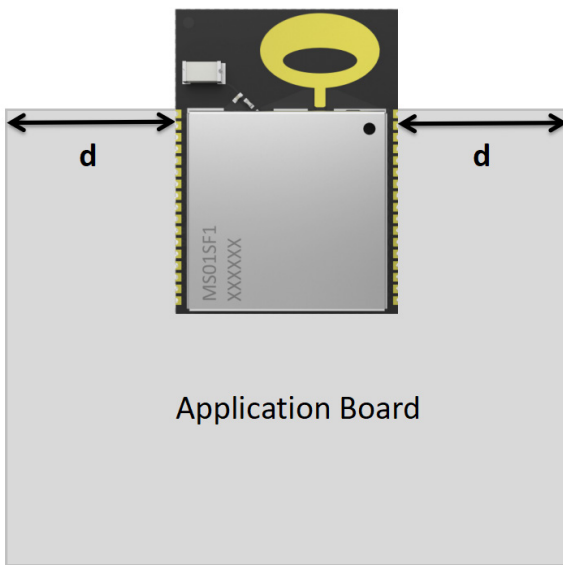

## 8 REFLOW AND SOLDERING

- 1) Do SMT according to above reflow oven temperature deal curve. Max. Temperature is  $260\text{ }^{\circ}\text{C}$ ; Refer to IPC/JEDEC standard; Peak  $\text{TEMP} < 260\text{ }^{\circ}\text{C}$ ; Times:  $\leq 2$  times, suggest only do once reflow soldering on module surface in case of SMT double pad involved. Contact us if special crafts involved.
- 2) Suggesting to make  $0.2\text{mm}$  thickness of module SMT for partial ladder steel mesh, then make the opening extend  $0.8\text{mm}$
- 3) After unsealing, it cannot be used up at one time, should be vacuumed for storage, couldn't be exposed in the air for long time. Please avoid getting damp and soldering-pan oxidizing. If there are 7 to 30 days interval before using online SMT, suggest to bake at  $65\text{-}70\text{ }^{\circ}\text{C}$  for 24 hours without disassembling the tape.
- 4) Before using SMT, please adopt ESD protection measure.

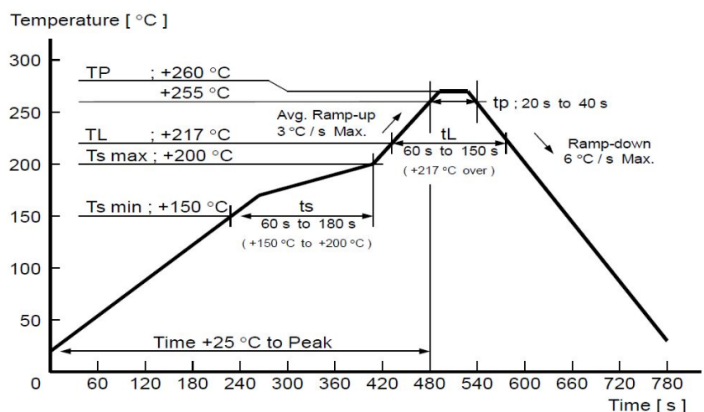



# 9 PACKAGE INFORMATION

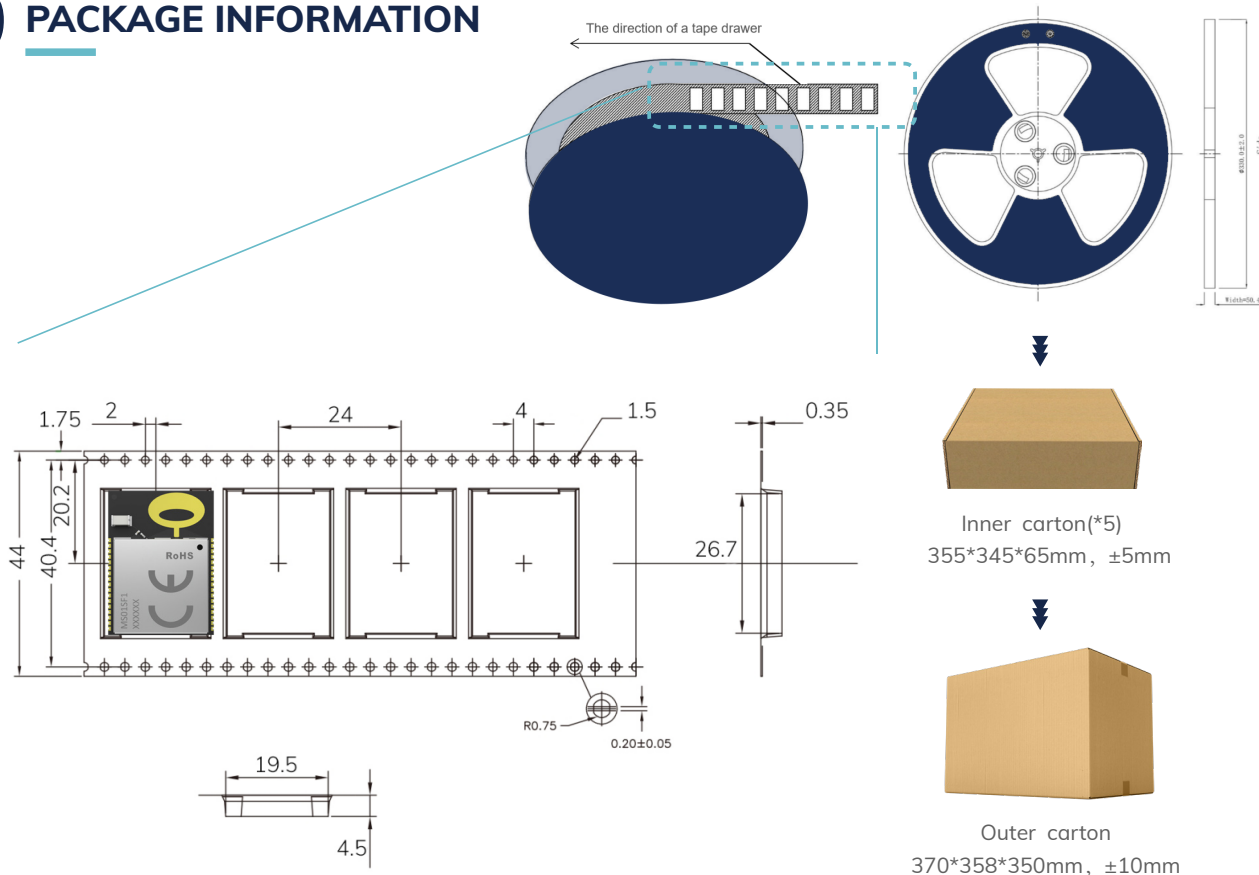

## Remarks

General material list for FCL packaging:

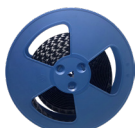

Carrier tape packaging tray

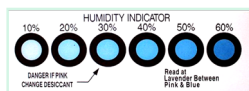

Humidity Indicator  
(1 pcs/bag)



Desiccant  
(placed in a vacuum bag)



Vacuum bag



Inner carton(\*5)  
355\*345\*65mm, ±5mm



Outer carton  
370\*358\*350mm, ±10mm

### Other:

Moisture-proof label (attached to the vacuum bag)

Certification label (attached to the vacuum bag)

Outer box label

⚠ Default unit: mm Default tolerance: ±0.1

Packing detail	Specification	Net weight	Gross weight	Dimension
MS01SF1	550PCS	1038g	1508g	W=44mm, T=0.35mm

⚠ Note: Default weight tolerance all are within 10g (except the special notes)

## 10 STORAGE CONDITIONS

- Please use this product within 6 months after signing the receipt.
  - This product should be stored without opening the package at an ambient temperature of 5~35°C and a humidity of 20~70%RH.
  - This product should be left for more than 6 months after receipt and should be confirmed before use.
  - The product must be stored in a non-corrosive gas (Cl<sub>2</sub>, NH<sub>3</sub>, SO<sub>2</sub>, NO<sub>x</sub>, etc.).
  - To avoid damaging the packaging material, do not apply any excessive mechanical shocks, including but not limited to sharp objects adhering to the packaging material and product dropping.
- This product is suitable for MSL2 (based on JEDEC standard J-STD-020).
  - After opening the package, the product must be stored at ≤30°C/<60%RH. It is recommended to use the product within 3-6 months after opening the package.
  - When the color of the indicator in the package changes, the product should be baked before welding.
- Baking is not required for one year if exposure is limited to <30°C and 60%RH. Refer to MSL2 for exposure criteria for moisture sensitivity level. If exposed to (≥168h@85°C/60%RH) conditions or stored for more than one year, recommended baking conditions.
  1. 120 +5/-5°C, 8 hours, 1 time  
Products must be baked individually on heat-resistant trays because the materials (base tape, reel tape, and cover tape) are not heat-resistant, and the packaging material may be deformed at temperatures of 120 °C;
  2. 90 °C +8/-0 °C, 24hours, 1times  
The base tape can be baked together with the product at this temperature. Please pay attention to the uniformity of heat.

## 11 HANDLING CONDITIONS

- Be careful in handling or transporting products because excessive stress or mechanical shock may break products.
- Handle with care if products may have cracks or damages on their terminals. If there is any such damage, the characteristics of products may change. Do not touch products with bare hands that may result in poor solder ability and destroy by static electrical charge.

## 12 QUALITY

Cognizant of our commitment to quality, we operate our own factory equipped with state-of-the-art production facilities and a meticulous quality management system. We hold certifications for ISO9001, ISO14001, ISO27001, OHSAS18001, BSCI.

Every product undergoes stringent testing, including transmit power, sensitivity, power consumption, stability, and aging tests. Our fully automated module production line is now in full operation, boasting a production capacity in the millions, capable of meeting high-volume production demands.

## 13 COPYRIGHT STATEMENT

This manual and all the contents contained in it are owned by Shenzhen Minewsemi Co., Ltd. and are protected by Chinese laws and applicable international conventions related to copyright laws.

The certified trademarks included in this product and related documents have been licensed for use by MinewSemi. This includes but is not limited to certifications such as BQB, RoHS, REACH, CE, FCC, BQB, IC, SRRC, TELEC, WPC, RCM, WEEE, etc. The respective textual trademarks and logos belong to their respective owners. For example, the Bluetooth® textual trademark and logo are owned by Bluetooth SIG, Inc. Other trademarks and trade names are those of their respective owners. Due to the small size of the module product, the "®" symbol is omitted from the Bluetooth Primary Trademarks information in compliance with regulations.

The company has the right to change the content of this manual according to the technological development, and the revised version will not be notified otherwise. Without the written permission and authorization of the company, any individual, company, or organization shall not modify the contents of this manual or use part or all of the contents of this manual in other ways. Violators will be held accountable in accordance with the law.

## 14 RELATED DOCUMENTS

- nRF52833\_Chip\_Datasheet  
[https://en.minewsemi.com/file/nRF52833\\_Chip\\_Datasheet\\_EN.pdf](https://en.minewsemi.com/file/nRF52833_Chip_Datasheet_EN.pdf)
- DW3000LR1110\_Chip\_Datasheet  
[https://en.minewsemi.com/file/DW3000LR1110\\_Chip\\_Datasheet\\_EN.pdf](https://en.minewsemi.com/file/DW3000LR1110_Chip_Datasheet_EN.pdf)
- MinewSemi\_Product\_Naming\_Reference\_Manual\_V1.0  
[https://en.minewsemi.com/file/MinewSemi\\_Product\\_Naming\\_Reference\\_Manual\\_EN.pdf](https://en.minewsemi.com/file/MinewSemi_Product_Naming_Reference_Manual_EN.pdf)
- MinewSemi\_Connectivity\_Module\_Catalogue\_V2.0  
[https://en.minewsemi.com/file/MinewSemi\\_Connectivity\\_Module\\_Catalogue\\_EN.pdf](https://en.minewsemi.com/file/MinewSemi_Connectivity_Module_Catalogue_EN.pdf)



For product change notifications and regular updates of Minewsemi documentation, please register on our website: [www.minewsemi.com](http://www.minewsemi.com)

# MINEWSEMI



### SHENZHEN MINEWSEMI CO., LTD.



0086-755-2801 0353



<https://minewsemi.com>



[minewsemi@minew.com](mailto:minewsemi@minew.com)



<https://store.minewsemi.com>



No.8, Qinglong Road, Longhua District, Shenzhen, China