

BLE Module

MS88SFB

DateSheet

V 1.1.0

Applicable Product Model

MS88SFB-nRF52833

Version Note

Version	Details	Contributor(s)	Date	Notes
1.0.0	First edit	Coral	2023.04.06	
1.1.0	Layout Changes	Michelle	2023.10.07	

MS88SFB-nRF52833

Low Power, PCB/IPEX(MHF 5) Selectable, Multi-Protocol Bluetooth 5.4 PA Module



The MS88SFB is a BLE5.4 PA/LNA module base on highly flexible and very low power-loss nRF52833 SoC. The strong 32-bit ARM Cortex™ M4F CPU, 512kB flash memory, 128kB RAM and integrated 2.4GH transceiver inside it providing wonderful solutions for Bluetooth connecting. nRF52833 is able to support ANT, BLE, BLE MESH, ZIGBEE and THREAD protocols, etc. Communication distance up to 600m under condition of 1Mbps rate and nRF21540 PA/LNA built in .

■ Features

- Bluetooth 5.4
- Built-in nRF21540 PA/LNA
- Power up to Maximum+20dbm
- PCB antenna and IPEX mount optional
- Communication distance up to 600m at 1Mbps rate
- Support ANT, BLE, BLE MESH, ZIGBEE and THREAD protocols, etc.

■ Application

- Smart Buildings
- Consumer Electronics
- Smart Healthcare
- Security Equipment
- Automotive Devices
- Smart Agriculture

■ Key parameter

Chip Model	nRF52833	Antenna	PCB/IPEX(MHF 5)
Module Size	23.2×17.4×2mm	GPIO	29
Flash	512KB	RAM	128KB
Receiving Sensitivity	-96dBm	Transmission Power	~ +20dBm

INDEX

1 Block Diagram	5
2 Electrical Specification	5
3 Pin Description	6
4 Pin Definition	7
5 Mechanical Drawing	8
6 Electrical Schematic	9
7 PCB Layout	10
8 Reflow and Soldering	12
9 Package Information	13
Quality	14
Contact Us	14
Copyright Statement	15

1 Block Diagram

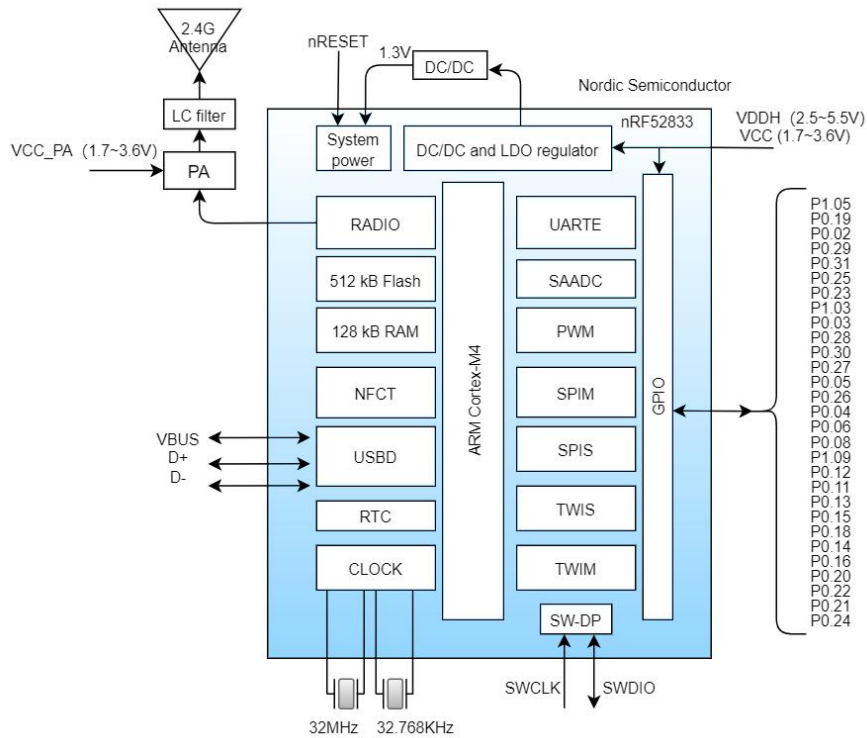

2 Electrical Specification

Parameter	Values	Notes
Working Voltage	1.7V-5.5V	To ensure RF work, supply voltage suggest not lower than 3V
Working Temperature	-40°C~+85°C	Storage temperature is -40°C~+125°C
Transmission Power	~ +20dBm	Configurable
Module Dimension	23.2*17.4*2mm	
Quantity of IO Port	29	

3 Pin Description

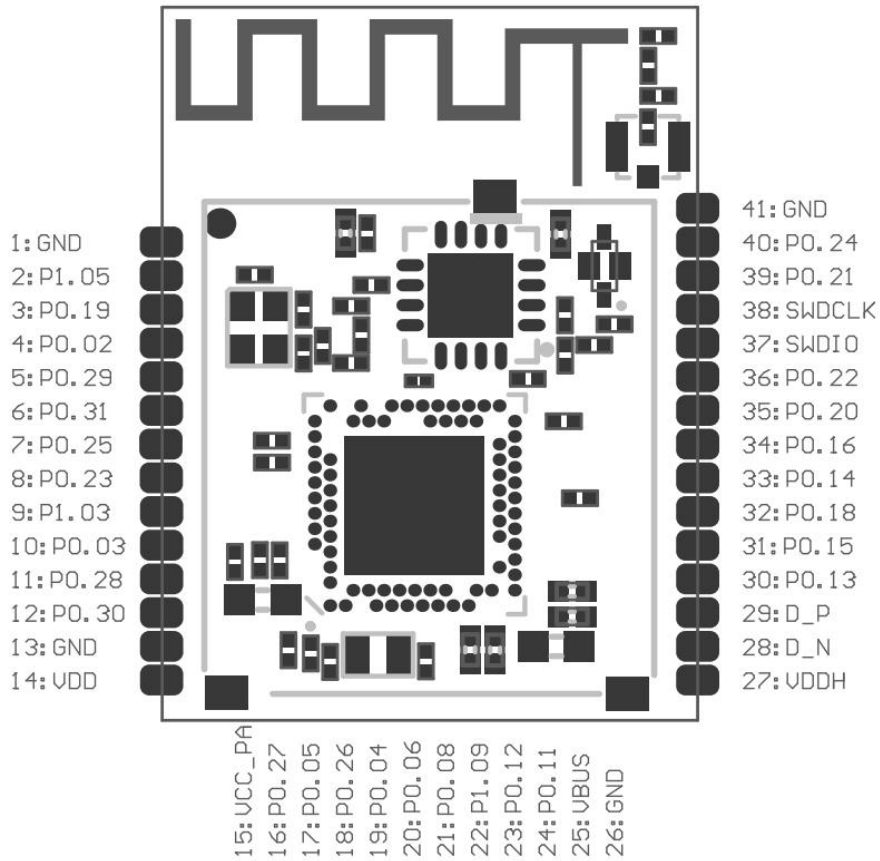

4 Pin Definition

Pin Number	Symbol	Type	Definition
14	VDD	Power source	Power supply: 1.7V-3.6V, short-circuit VDD and VDDH to use the pin to supply power
27	VDDH	Power source	Power supply: 2.5V-5.5V; When supply 5V electricity, use this pin to supply power, not connect VDD pin.
1/13/26/41	GND	Ground	Ground
37/38	SWCLK/ SWDIO	Debug	Debug, when debugging only need to connect power supply pin, ground and these 2 pins.
2-12/16-24/ 30-36/39-40	P0.02-P0.31 P1.00-P1.09	I/O	I/O port for general purpose
25	VBUS	Power source for USB port	5V input current for USB 3.3V modulator Need to supply 5V current and short-circuit this pin with VDDH When use USB port
15	VCC_PA	PA supply power pin	Must provide electricity of 2.7-3.6V stably, 1.7V-3.6V chip voltage, this pin can be shorted to VDD/VDDH
29	D+	Digital interfaces	USB D+
28	D-	Digital interfaces	USB D-

5 Mechanical Drawing

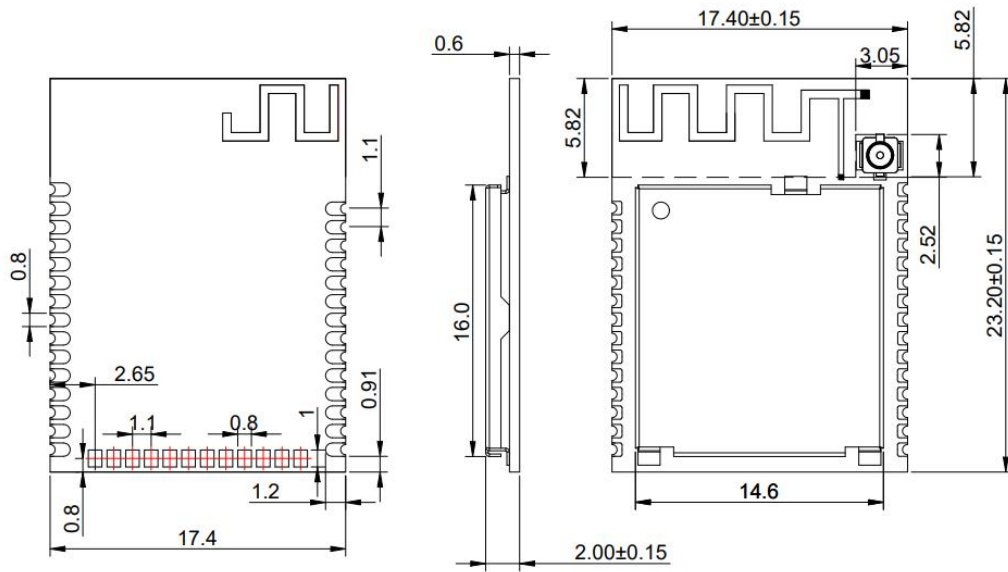

* (Default unit: mm Default tolerance: ±0.1)

Notice: The recommended pad size is 1.8*0.8mm with a pad extension of 0.5mm

6 Electrical Schematic

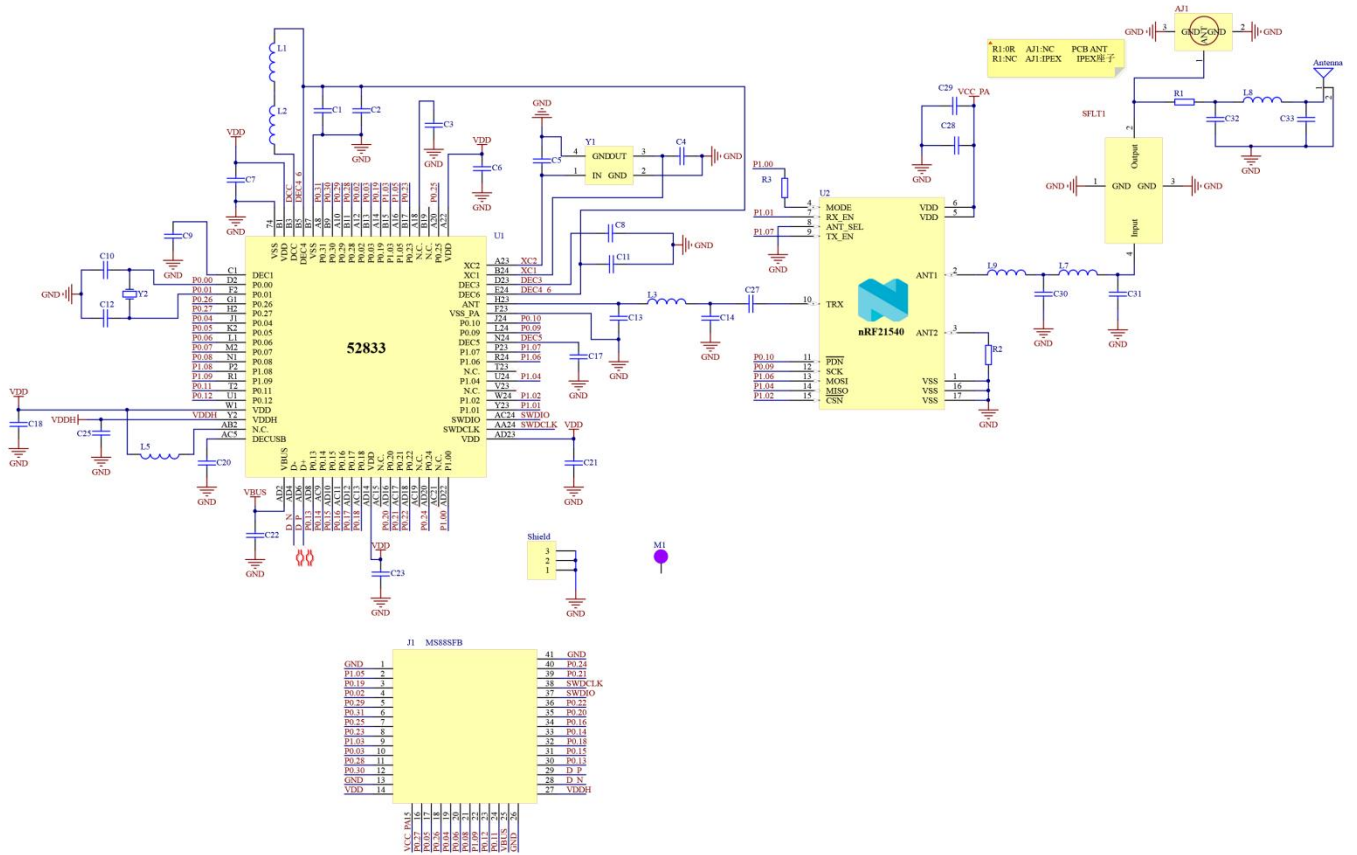

Notice: Before placing an order, please confirm the specific configuration required with the salesperson.

7 PCB Layout

Module antenna area couldn't have GND plane or metal cross line, couldn't place components nearby. It is better to make hollow out or clearance treatment or place it on the edge of PCB board.

Notice: Refer to examples as below, and highly suggest to use the first design and the adjustment of modules antenna design according to the first wiring.

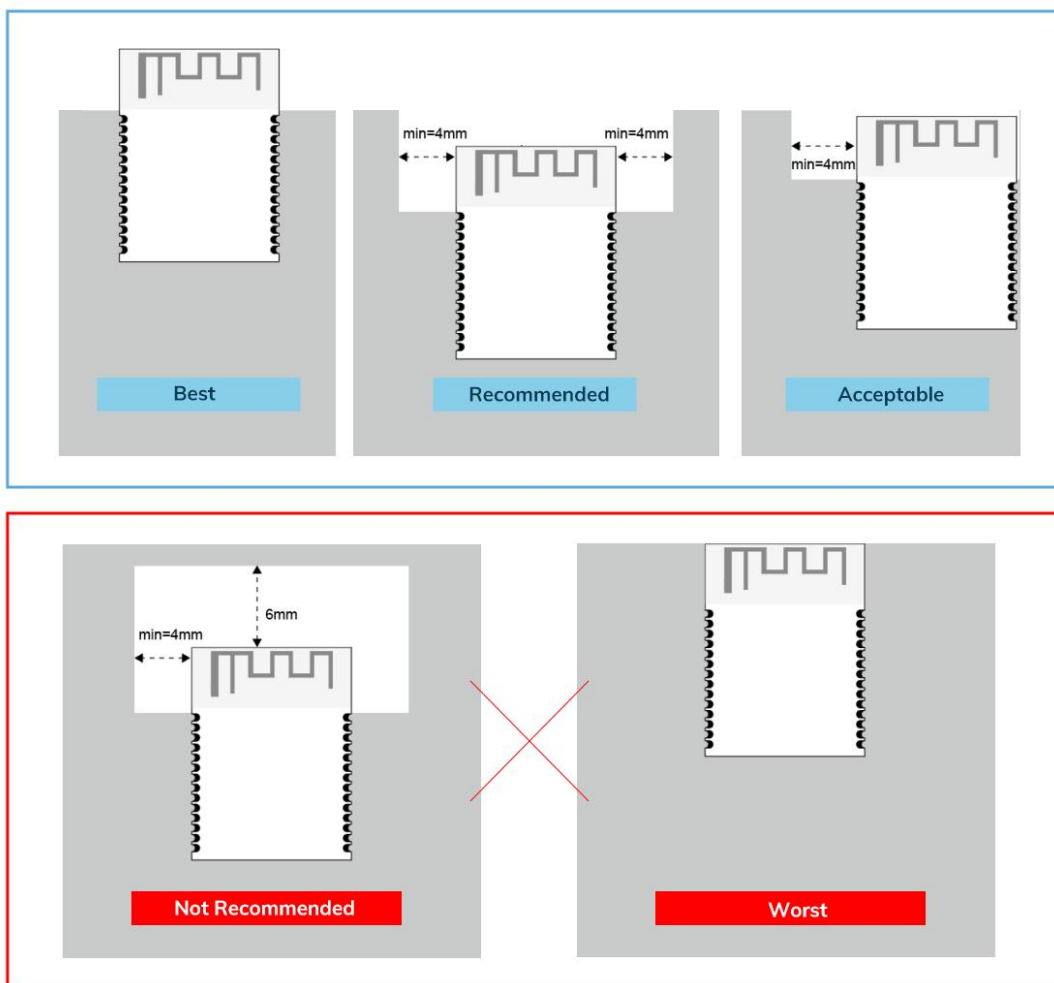

Layout notes:

- 1) Preferred Module antenna area completely clearance and not be prevented by metals, otherwise it will influence antenna's effect (as above DWG. indication).
- 2) Cover the external part of module antenna area with copper as far as possible to reduce the main board's signal cable and other disturbing.
- 3) It is preferred to have a clearance area of 4 square meter or more area around the module antenna (including the shell) to reduce the influence to antenna.
- 4) Device should be grounded well to reduce the parasitic inductance.
- 5) Do not cover copper under module's antenna in order to avoid affect signal radiation or lead to transmission distance affected.
- 6) Antenna should keep far from other circuits to prevent radiation efficiency reduction or affects the normal operation of other lines.
- 7) Module should be placed on edge of circuit board and keep a distance away from other circuits.
- 8) Suggesting to use magnetic beads to insulate module's access power supply.

8 Reflow and Soldering

1) Do SMT according to above reflow oven temperature deal curve. Max. Temperature is 260°C;

Refer to IPC/JEDEC standard; Peak TEMP<260°C; Times: ≤2 times, suggest only do once reflow soldering on module surface in case of SMT double pad involved. Contact us if special crafts involved.

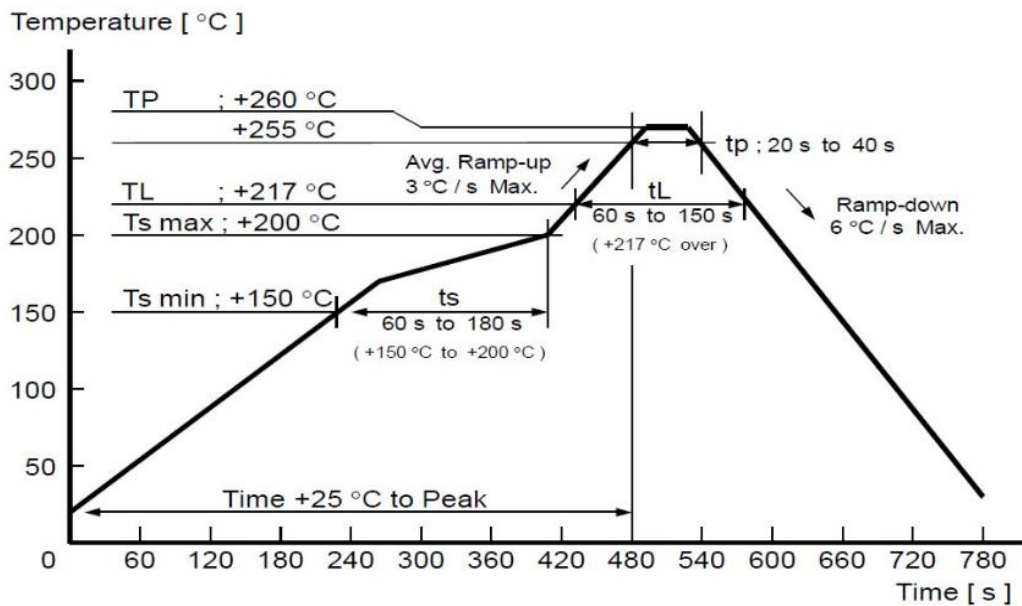

- 2) Suggesting to make 0.2mm thickness of module SMT for partial ladder steel mesh, then make the opening extend 0.8mm
- 3) After unsealing, it cannot be used up at one time, should be vacuumed for storage, couldn't be exposed in the air for long time. Please avoid getting damp and soldering-pan oxidizing. If there are 7 to 30 days interval before using online SMT, suggest to bake at 65-70 °C for 24 hours without disassembling the tape.
- 4) Before using SMT, please adopt ESD protection measure.

9 Package Information

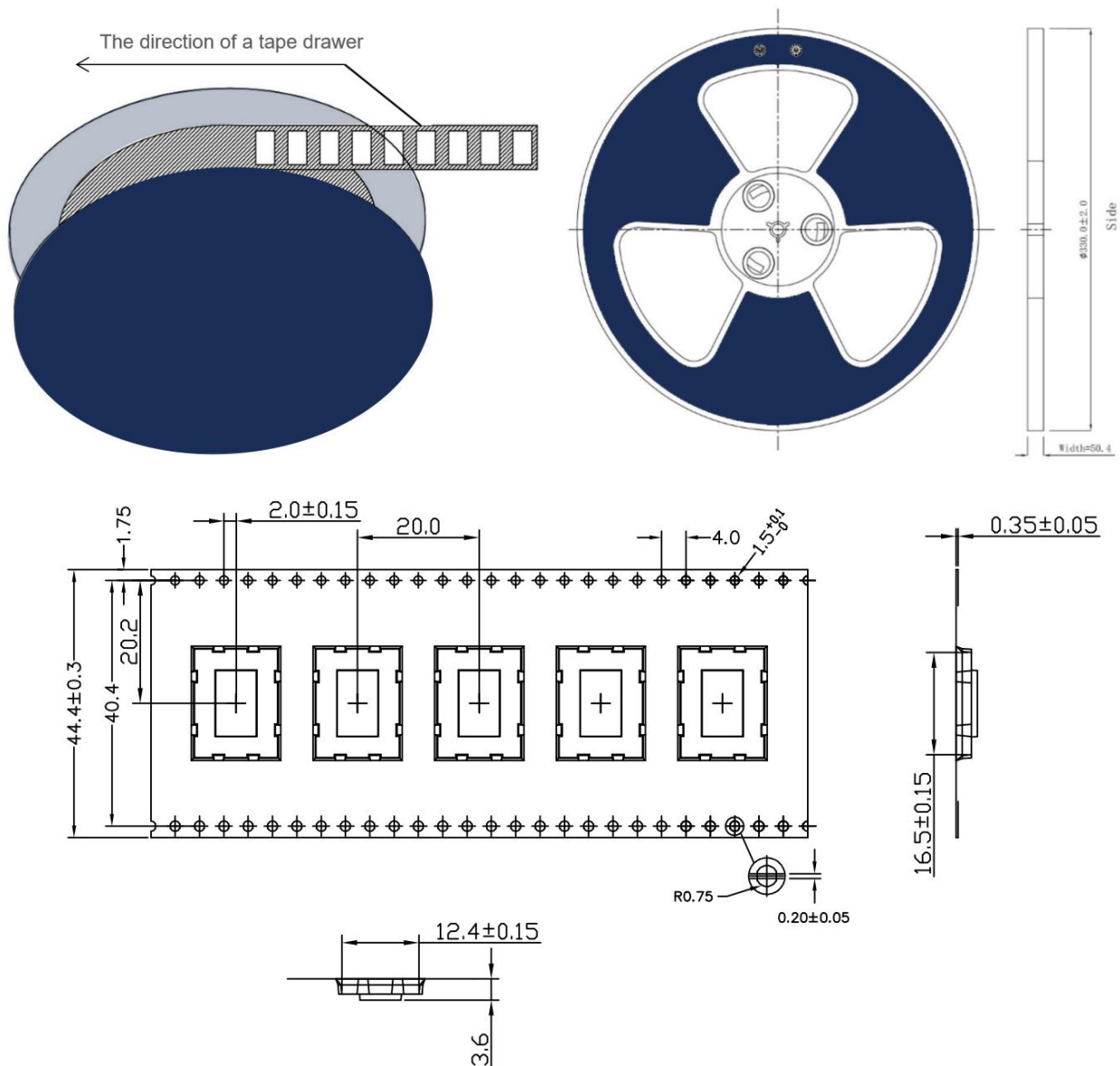

* (Default unit: mm Default tolerance: ± 0.1)

Packing detail	Specification	Net weight	Gross weight	Dimension
Quantity	650PCS	780g	1520g	W: 44mm,T:0.35mm

*** Note:** Default weight tolerance all are within 10g (except the special notes)

● Quality

Cognizant of our commitment to quality, we operate our own factory equipped with state-of-the-art production facilities and a meticulous quality management system. We hold certifications for ISO9001, ISO14001, ISO27001, OHSAS18001, BSCI.

Every product undergoes stringent testing, including transmit power, sensitivity, power consumption, stability, and aging tests. Our fully automated module production line is now in full operation, boasting a production capacity in the millions, capable of meeting high-volume production demands.

● Contact Us

Shenzhen Minewsemi Co., Ltd. is committed to swiftly delivering top-quality connectivity modules to our customers. For assistance and support, please feel free to contact our relevant personnel, or contact us as follows:

Web: www.minewsemi.com

Email: minewsemi@minew.com

Linkedin: www.linkedin.com/company/minewsemi

Shop: <https://minewsemi.en.alibaba.com/>

Tel: +86 0755-28010353

Address: 3rd Floor,I Building, Gangzhilong Science Park, NO.6, Qinglong Road,Longhua District, Shenzhen, China

Click the icon to view and download the latest product documents electronically.



Related documents: Chip specification

● Copyright Statement

This manual and all the contents contained in it are owned by Shenzhen Minewsemi Co., Ltd. and are protected by Chinese laws and applicable international conventions related to copyright laws.

The certified trademarks included in this product and related documents have been licensed for use by MinewSemi. This includes but is not limited to certifications such as BQB, RoHS, REACH, CE, FCC, BQB, IC, SRRC, TELEC, WPC, RCM, WEEE, etc. The respective textual trademarks and logos belong to their respective owners. For example, the Bluetooth® textual trademark and logo are owned by Bluetooth SIG, Inc. Other trademarks and trade names are those of their respective owners. Due to the small size of the module product, the "@" symbol is omitted from the Bluetooth Primary Trademarks information in compliance with regulations.

The company has the right to change the content of this manual according to the technological development, and the revised version will not be notified otherwise. Without the written permission and authorization of the company, any individual, company, or organization shall not modify the contents of this manual or use part or all of the contents of this manual in other ways. Violators will be held accountable in accordance with the law.

MINEWSEMI

Tel: 0086-755-2801 0353

Email: minewsemi@minew.com

Web: www.minewsemi.com

Address: 3rd Floor, Building I, Gangzhilong Science Park, Qinglong Road Longhua District, Shenzhen 518109, China

