

BLE Module

MS48SF2

Datasheet

V 1.3.0

Applicable Product Model
MS48SF2-M1805

Version Note

Version	Details	Contributor(s)	Date	Notes
1.0.0	First edit	Coral	2020.5.21	
1.1.0	Firmware Program Supplement	Coral	2021.2.8	
1.2.0	Layout change	Coral	2022.4.20	
1.3.0	Style change	Michelle	2023.8.30	

MS48SF2-M1805

Bluetooth transparent slave module with high cost-effectiveness and support for serial command configuration



PCB

MS48SF2 is a module designed using the M1805 chip with Bluetooth slave device firmware, which has broadcast and connection status. It uses the UART interface to transparently transmit data between the mobile phone/tablet and the MCU, without the need for Bluetooth development to add Bluetooth functionality to the product and provide convenience for product development. The device broadcast communicates with the MCU through the UART interface. In broadcast mode, the MCU can set and view the module's broadcast name in command format, set custom data, modify parameters such as broadcast interval and connection interval through the UART interface. When a host connects to a device through Bluetooth, the device will act as a bridge between the host and the MCU for transparent data transmission.

■ Features

- The fastest transmission rate can reach 11kB/s
- Support serial port instruction configuration
- With shielding cover

■ Certification information

CE、FCC、SRRC

■ Application

Smart home,
 smart wearable devices,
 consumer electronics,
 smart healthcare,
 security equipment,
 automotive equipment,
 sports and fitness equipment,
 instruments and meters

■ Key parameter

Chip Model	M1805	Antenna	PCB
Module Size	15.8×12×2mm	GPIO	12
Flash	512kB	RAM	138KB
receiver sensitivity	-97dBm	Transmitting power	-40~ +5dBm
Emission Current	0dBm-8mA	Receiving Current	8mA
firmware	Transparent Slave Firmware		

INDEX

1 Block Diagram	6
2 Electrical Specification	6
3 Current Consumption Characteristics	7
4 Pin Description	8
5 Pin Definition	9
6 Module Operation Instruction	10
6.1 Tool	10
6.2 Demonstration of module application	10
6.2.1 Power supply	11
6.2.2 SLP(Sleep/Awake)	11
6.2.3 BTDATA(UART control)	11
6.2.4 UART interface:TX and RX	11
6.2.5 CON_IND	12
6.2.6 FIFO_FULL	12
6.2.7 Command instruction	12
6.3 Example of operation	14
6.3.1 Factory Default Parameters	14
6.3.2 Broadcast packet (broadcast packet+reply packet)	15
6.3.3 Example of modifying parameters	16
6.3.4 Transparent transmission	17
7 Mechanical Drawing	19

8 Electrical Schematic	20
9 PCB Layout	21
10 Reflow and Soldering	23
11 Package Information	24
Quality	25
Contact Us	25
Copyright Statement	26

1 Block Diagram

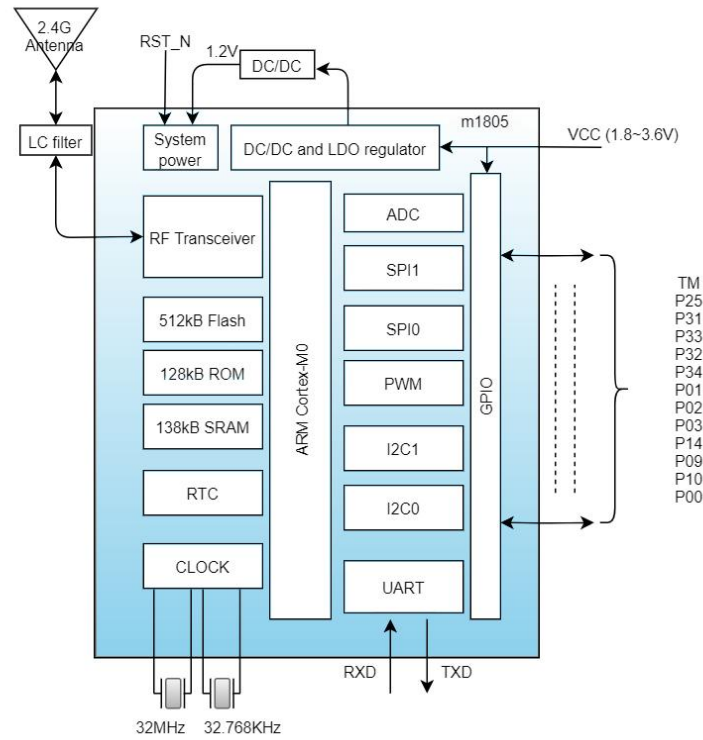

2 Electrical Specification

Parameter	Values	Notes
Working Voltage	1.7V-3.6V	To ensure RF work, supply voltage suggest not lower than 2.3V
Working Temperature	-40°C~+85°C	Storage temperature is -40°C~+125°C
Transmission Power	-45 ~ +5dBm	Configurable
Receiving Current	8mA	RF reception current in 1Mbps mode
Emission Current	8mA	RF emission current in 0dB mode
Module Dimension	15.8*12*2mm	
Quantity of IO Port	12	

3 Current Consumption Characteristics

The following power consumption test is conducted at room temperature with a power supply voltage of 3.3V. The broadcast interval is 1s, and the maximum and minimum connection interval is 20-40ms. The calculation of service life is generally based on the average power consumption (Avg).

Status	Consumption	Peak(mA)	Avg(mA)
	Average current in sleep state (SLP pulled high, BTDATA pulled low)	4.589	0.015
	Broadcast average current (SLP pin is connected to GND, BTDATA is pulled high)	10.494	0.024
	Connection state average current (SLP pin is connected to GND, BTDATA is pulled high)	9.281	0.457
	Transparent transmission average current (SLP, BTDATA pins are connected to GND, connected to mobile phones)	10.842	2.925

4 Pin Description

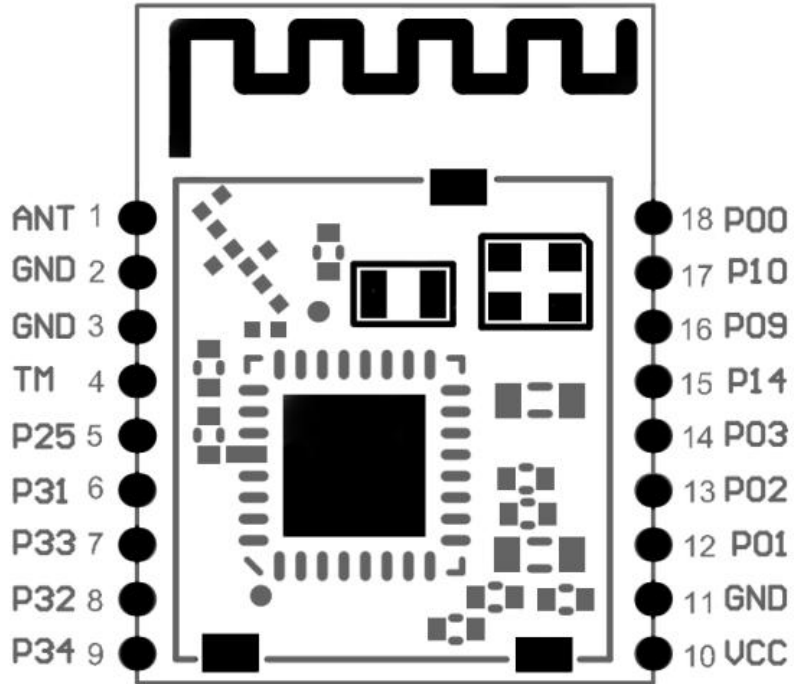

5 Pin Definition

Pin Number	Symbol	Type	Definition	Note
1	ANT		External antenna pins	Using the module's built-in antenna, this pin is directly suspended in the air. If the module's built-in antenna is not used, the antenna can be externally connected through this pin. When connecting the antenna, the resistor connected to the antenna needs to be horizontally welded to this pin
2~3	NC			
4	TM		Test_Mode	Burn control pin, enter burn mode when high, suspend or ground in application mode
5-7	P25 to P33		GPIO	Not used in UART, floating
8	P32	BTX	UART TX	TX of Bluetooth Module
9	P34	BRX	UART RX	RX of Bluetooth Module
10	VCC	VCC	Power Supply	
11	GND	GND	Ground	
12	P01	CON_IND	Connection indication	Sleep state: low level Broadcast status: Low level Connection status: High level
13	P02	FIFO_FULL	Transmission space full	Determine if the transmission space is available when it is full 0: Bluetooth module has available space for transmission 1: Host stops transmitting and waits for free space to be released
14	P03	SLP	Sleep/Awake	Low level to wake-up, high level to sleep, no floating
15	P14	BTDATA	Serial port control	Serial port on / off to control pin, no floating 0: serial port open, can send and receive serial port data 1: Serial port off
16	P09		Burn clock pin	Used for burning firmware
17	P10		Burn data pin	Used for burning firmware
18	P00		GPIO	Not used in UART, floating

6 Module Operation Instruction

6.1 Tool

Mobile app: Minew serial port assistant, nRF connect (also known as nRF Master Control Panel). When testing BLE products, it is not possible to use the built-in Bluetooth directly when using the system settings, especially on the IOS end. The Bluetooth settings inside will not display BLE devices.

Download the IOS directly from the APP store.

PC serial port assistant: Baidu "Friendly Serial Port Assistant" can be downloaded. The PC serial port assistant is used to debug the UART interface of the module.

6.2 Demonstration of module application

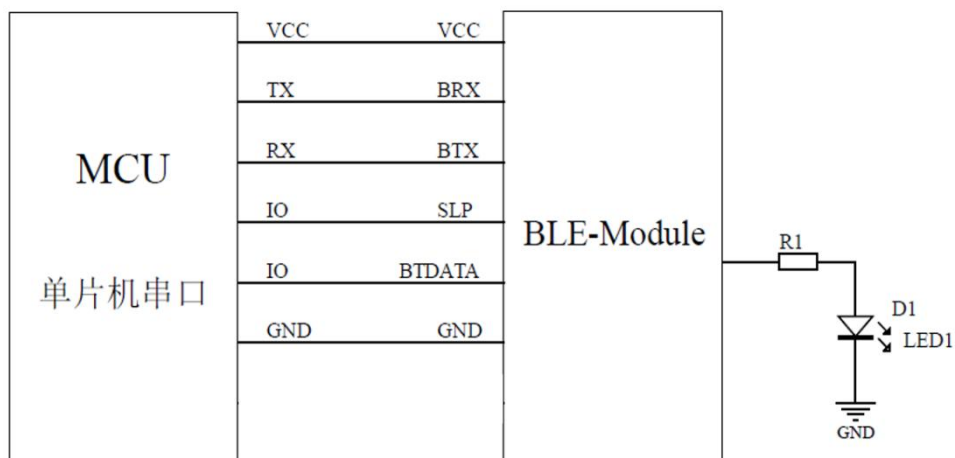

6.2.1 Power supply

The SoC working voltage is 1.7V-3.6V, to ensure a stable function, supply voltage should be 3.0V-3.6V.

6.2.2 SLP(Sleep/Awake)

When pull SLP low, the module in broadcast mode. BLE device can be found by smartphone APP, Device name: Minew_Vxxxxx(default) name, module can be connected with smartphone and enters connection mode. When pull SLP high, device will enter sleep mode.

Note: This pin cannot be left floating to avoid unpredictable errors.

6.2.3 BTDATA(UART control)

The BTDATA pin is only valid when SLP is low. SLP is low, BTDATA is low, and when the module is in a broadcast state, all UART data will be considered as instructions. When the module is connected, all data is considered transparent.

Note: This pin cannot be left floating to avoid unpredictable errors.

6.2.4 UART interface:TX and RX

When both SLP and BTDATA in low level,UART port will be activated,the module TX and RX should be connected to MCU RX and TX,then start to communicate through UART.

In the test,module TX and RX can be connected with an UART to USB module's RX and TX pin, then send command through Serial Port Utility App from PC.

Note: The TX and RX of 2 modules can be connected reversed, each module connect with a smart phone, then transfer data over BLE between each smart phone.

6.2.5 CON_IND

CON_IND is used to indicate module status, high level in connection mode, low level in sleep or broadcast mode to wake up MCU and save power.

6.2.6 FIFO_FULL

FIFO_FULL is used to indicate whether the cache is full or not. When sending large amount of data from MCU to module, this pin can be added to judge. If it is high, then the FIFO is full, and you can not continue to send UART data at this time to avoid packet loss.

6.2.7 Command instruction

After connecting VCC and GND, the SLP and BTDATA pins are directly grounded. At this time, the module is in an unconnected state, that is, the module is in command mode and the serial port is turned on. Instructions can be sent to set and query parameters.

For all device instructions, the returning result is the same:

54544D3A4F4B0D0A00(TTM:OK\r\n\0) is returned after command sent successfully

54544D3A4552500D0A00 (TTM:ERP\r\n\0) is returned after command failed

After sending the correct setting command, the parameters take effect immediately (the baud rate only takes effect after sending the reset command), and the power outage will not be saved at this time. Only after sending the reset command will it be saved to flash.

Below is the list of setup instructions:

Note: The first line in the command list should be sent by Hex format, the second line should be sent by ASCII format. When checking the parameter, the returned result are all hexadecimal numbers, so you need to use hexadecimal numbers to parse the command.

Function	Command (hex/ASCII)	Description
Setting the broadcast name	54544D3A52454E2D<Para>	Length: 1-16 Byte, Value: ASCII
	TTM:REN-<Para>	
Setting the broadcast interval	54544D3A41444502D<Para>	Length: 1 Byte, value: 1-20, corresponding to broadcast interval 1*100ms.
	TTM:ADP-<Para>	
Setting the Connection Interval	54544D3A4349542D<Para>	Length: 1 Byte, value: 1-100, corresponding to minimum connection interval Para * 10ms, maximum connection interval=minimum connection interval+10ms
	TTM:CIT-<Para>	
Setting the baud rate	54544D3A4250532D<Para>	Length: 1 Byte, values: 0-4, corresponding to 9600/19200/38400/57600/115200 (unit: bps)
	TTM:BPS-<Para>	
Setting the transmit power	54544D3A54504C2D<Para>	Length: 1 Byte, Values: 0-8, corresponding to -40, -20, -16, -12, -8, -4, 0, +4, +8 (unit: dB)
	TTM:TPL-<Para>	
Setting the broadcast data	54544D3A4144442D<Para>	Length: 1-16 Byte, value: any hexadecimal number
	TTM:ADD-<Para>	
Setting the factory ID	54544D3A5049442D<Para>	Length: 2 Byte, value: any hexadecimal number
	TTM:PID-<Para>	
Setting the Service UUID	54544D3A5549442D <Para> TTM:UID-<Para>	Length: 6Byte, (2 Byte service uuid+2 Byte rx UUID+2 Byte tx UUID) Values: Any hexadecimal number, service, rx, tx UUID can't be the same.
Read MAC address	54544D3A4D41432D3F	Retro al 54544D3A4D41432XXXXXXXXXX20D0A
	TTM:MAC-?	
Read Broadcast Name	54544D3A444E4D2D3F	Retro al 54544D3A444E4D2D3FXXXXXXXXX0D0A00
	TTM:DNM-?	
Read version information	54544D3A5645522D3F	Direkte revenu 54544D3A5645522D56XXXXXXXXXXXXXXXXX0D0A00, eraro returnis TTM: ERP
	TTM:VER-?	
Restore factory equipment	54544D3A5253542D464143	Consistent with setting instruction return
	TTM:RST-FAC	
reset	54544D3A525342D535953	Modify the confirmation command, the command is correct and there is no return

6.3 Example of operation

6.3.1 Factory Default Parameters

Broadcast Name: Minew_Vxxxxx

Serial port baud rate: 9600bps,8N1

Transmit power: 0dBm

Broadcast interval: 1s

Broadcast mode: transparent broadcast package

Custom data: Minew Tech

Minimum and maximum connection interval: 20ms - 40ms

DC_RC: DCDC on, external 32K

6.3.2 Broadcast packet (broadcast packet+reply packet)

Use nrf connect to scan the device, click Raw after scanning to the device, Raw data is the unparsed data of the scanned device. After parsing the data according to BLE data type, see Detail section, BLE broadcast data has a certain format: length + type + content.

The content is changeable, the type is fixed and the length is determined by the content. There are two broadcast formats for the device, the pass-through broadcast packet and the iBeacon broadcast packet. Both formats contain four types: flag(0x01), broadcast name(0x09), service data(0x16), and manufacturer data(0xFF).

The following figure shows the transmitting broadcast packet: flag, broadcast name, service data is put in the broadcast packet, manufacturer data is put in the reply packet. The service data content is: service data UUID(E1FF) + MAC address. manufacturer data content consists of company id(3906) + battery level information(1 byte) + custom data.

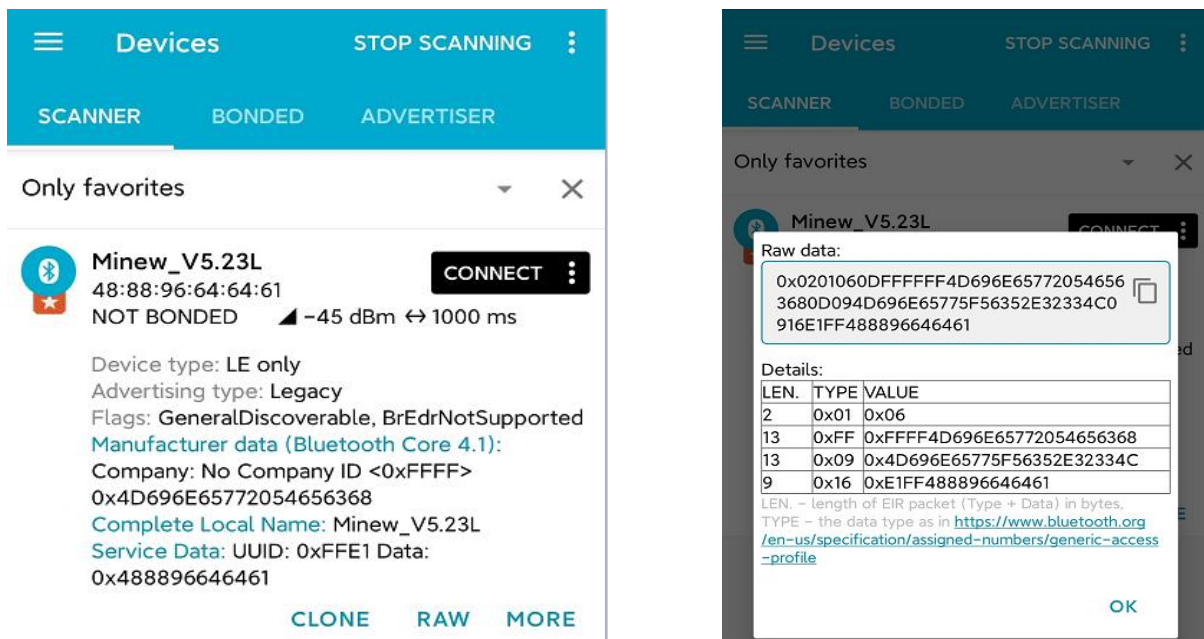

Note: The IOS side can not get the content of the MAC address field, so the MAC address is put back into the broadcast packet to ensure that the IOS side can get the device MAC address. In addition, the WeChat applet can't get the reply packet, so the MAC is put into the service data of the broadcast packet to ensure that the IOS side can also get the device MAC address using the WeChat applet connection.

6.3.3 Example of modifying parameters

Connect all pins according to the wiring method, with SLP and BTDATA grounded. At this time, the broadcast name can be viewed through the mobile app (Minew serial assistant or nRF connect) as Minew_ Vxxxxx device. In this state, if the serial port sends TTM: REN XXXXXX, it will return TTM: OK r n 0. At this time, you can see that the broadcast name has been modified on the mobile phone. If it is necessary to save the modified content after power down, a reset command needs to be sent before power down saving can be achieved.

Note: When multiple parameters need to be modified, all setting commands can be sent first, and then reset commands can be sent.

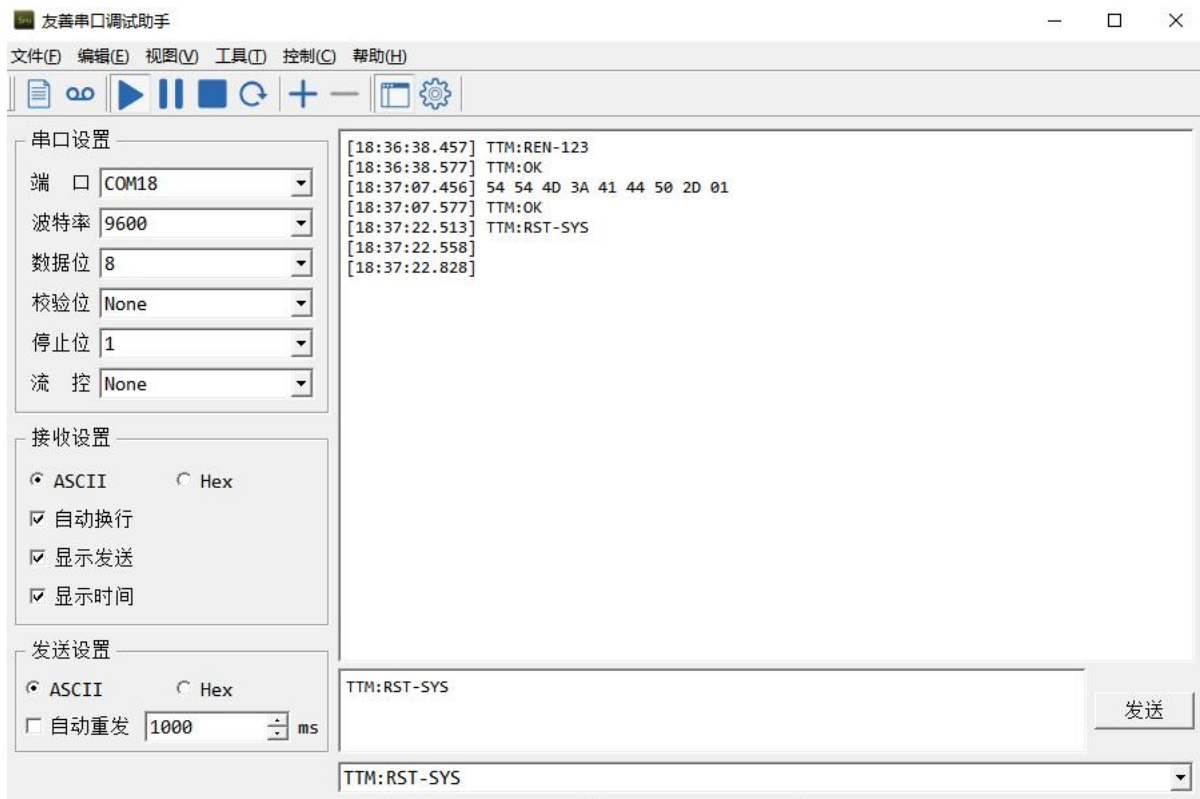

6.3.4 Transparent transmission

Based on 7.3, connect to the device using the mobile app and keep the BTDATA pin low to perform data passthrough. when BTDATA is not low, it does not affect the broadcasting and connecting of the device, just that passthrough is not possible. Using nRF connect, you can see the specific service, characteristic and corresponding properties.

The UUID consists of the alias UUID (2 byte, 3.4 byte on the left in the figure) + the base UUID (the remaining 14 byte).

The base UUID used for services, features in the passthrough program is standard and is illustrated below with the alias UUID.

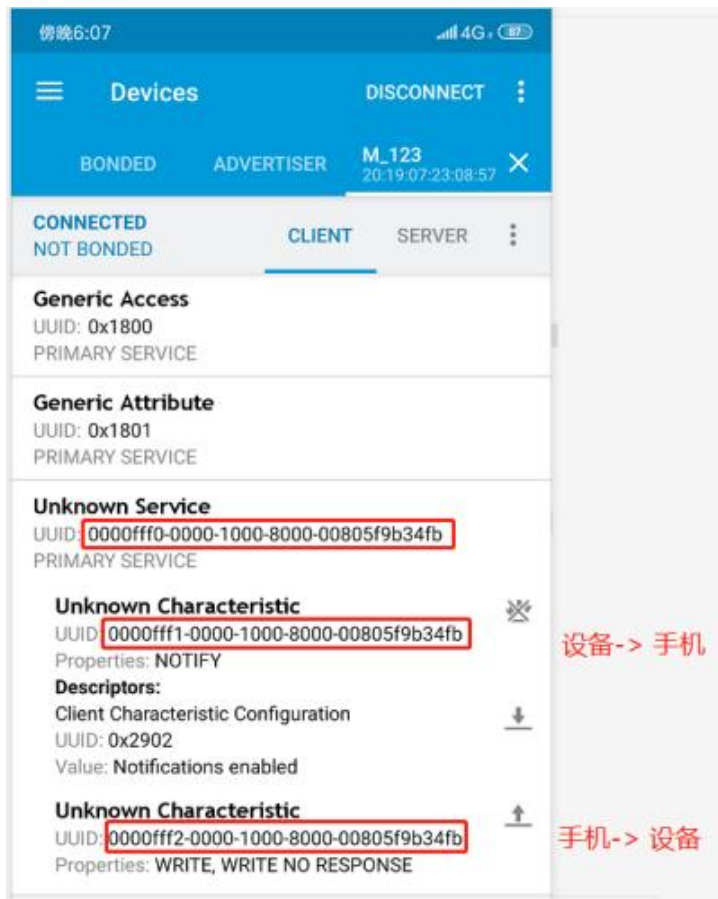

FFF0 is the service UUID, FFF1 is the cell phone receives data and the module sends data; FFF2 is the cell phone sends data and the module receives data.

Eigenvalue UUID	executable operation	Maximum Packet Length	note
FFF1	notify	20	<p>The serial port sends data to the module and forwards it to the phone. Data can only be obtained after the phone is enabled to notify. The maximum number of bytes emitted by a module packet is 244 bytes</p> <p>Note: This process is automatically subcontracted by the firmware, and it is not necessary to subcontract according to the length of a packet. However, the maximum length of each packet cannot exceed 512, and the transmission interval needs to consider the rate, otherwise it may cause packet loss, disconnection, and other situations.</p>
FFF2	write	20	<p>The mobile phone sends data to the module and forwards it to the serial port.</p> <p>Note: When calling the write data API on the mobile end, due to the module's subcontracting reception, the write data length can exceed 20, with a maximum support of 360. However, the underlying data is still sent and received in 20 bytes.</p>

7 Mechanical Drawing

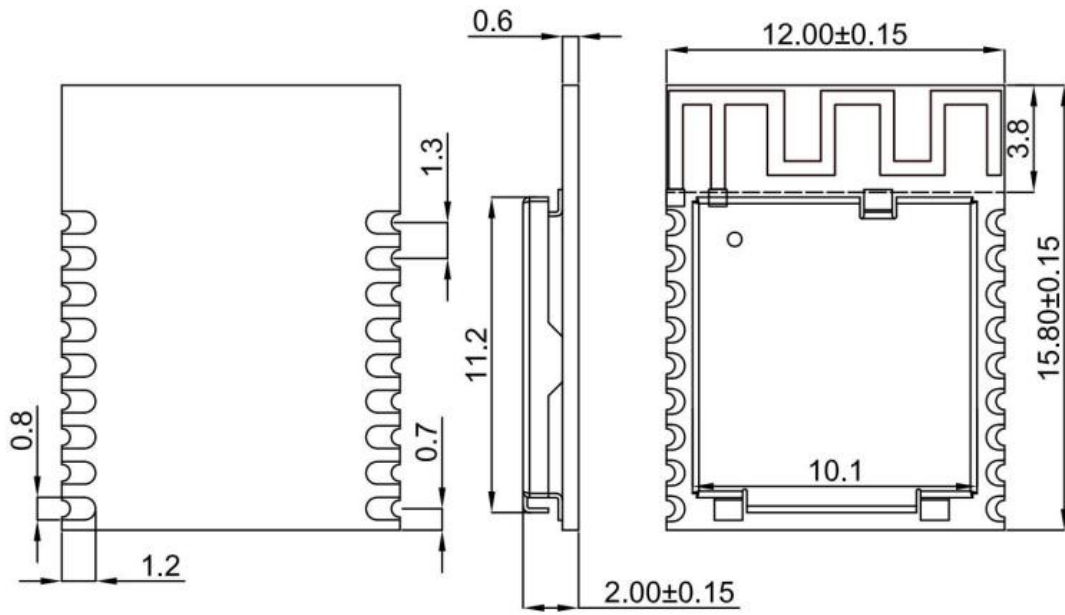

(Default unit: mm Default tolerance: ± 0.1)

Note: Recommended pad size 1.8*0.8mm, pad extends outward 0.5mm

8 Electrical Schematic

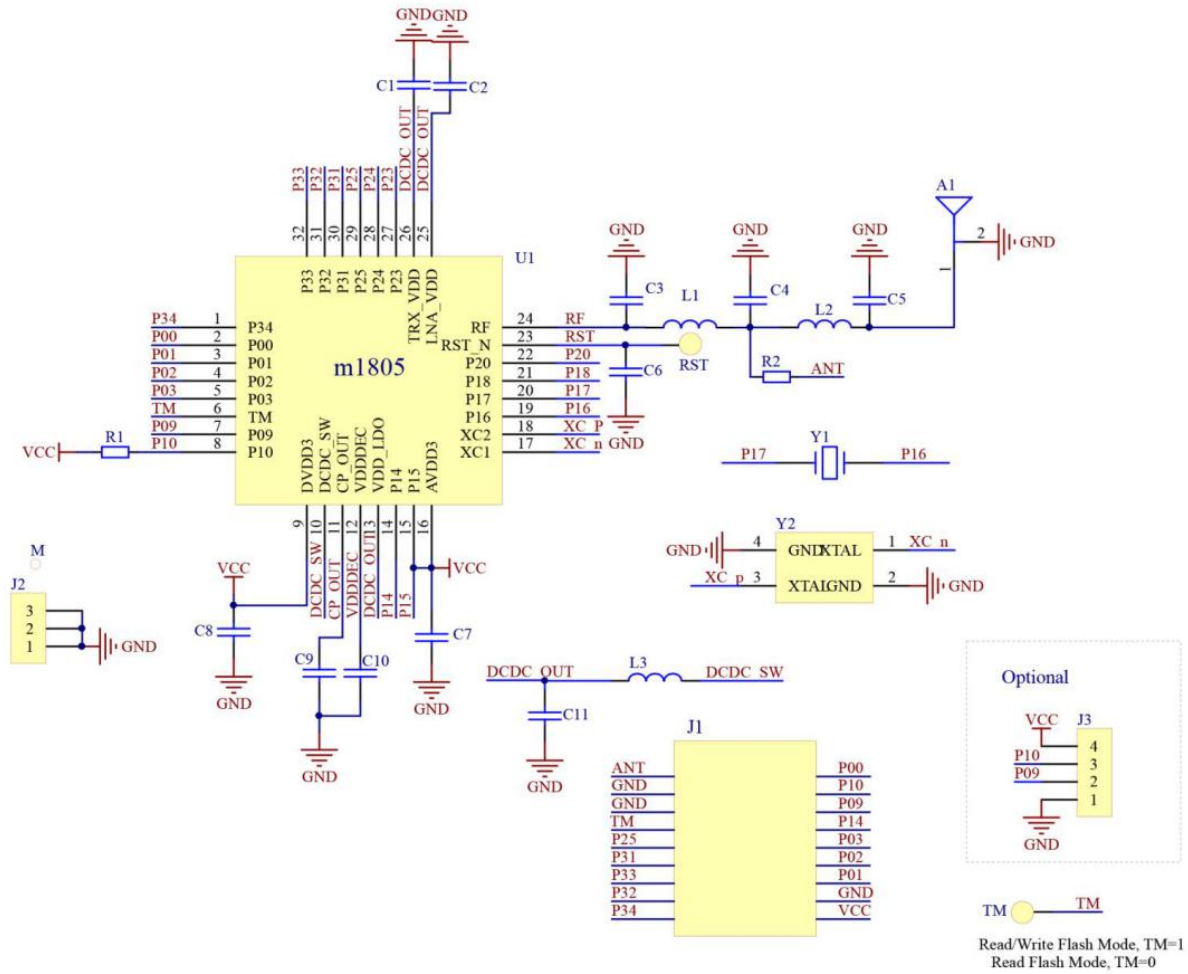

Notice: Before placing an order, please confirm the specific configuration required with the salesperson.

9 PCB Layout

Module antenna area can not have GND plane or metal cross wiring, can not be placed near the components, it is best to do skeletonization or headroom area processing, or placed on the edge of the PCB board. Reference examples are as follows

it is strongly recommended to use the first design, the module antenna design in accordance with the first wiring for debugging.

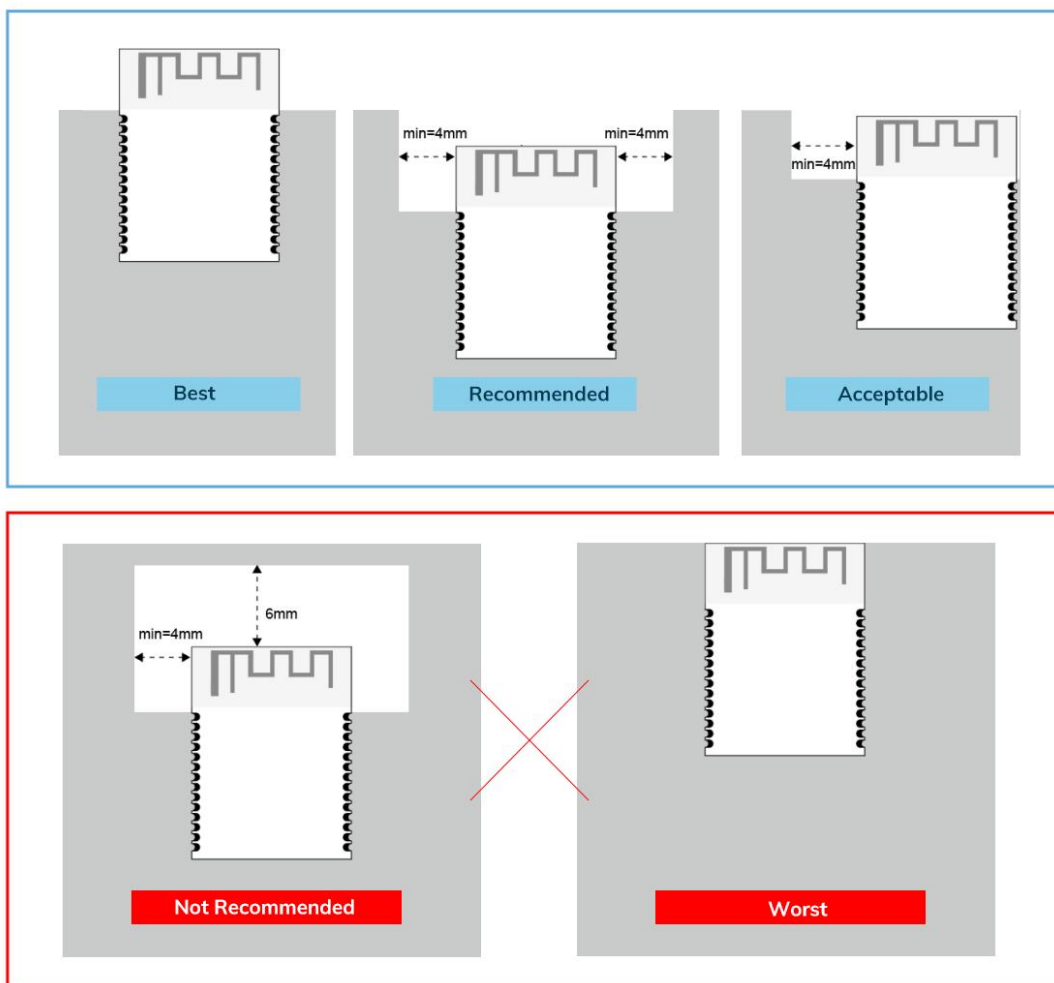

Layout notes:

- 1) Preferred Module antenna area completely clearance and not be prevented by metals, otherwise it will influence antenna's effect (as above DWG. indication).
- 2) Cover the external part of module antenna area with copper as far as possible to reduce the main board's signal cable and other disturbing.
- 3) It is preferred to have a clearance area of 4 square meter or more area around the module antenna (including the shell) to reduce the influence to antenna.
- 4) Device should be grounded well to reduce the parasitic inductance.
- 5) Do not cover copper under module's antenna in order to avoid affect signal radiation or lead to transmission distance affected.
- 6) Antenna should keep far from other circuits to prevent radiation efficiency reduction or affects the normal operation of other lines.
- 7) Module should be placed on edge of circuit board and keep a distance away from other circuits.
- 8) Suggesting to use magnetic beads to insulate module's access power supply.

10 Reflow and Soldering

- 1) Do SMT according to above reflow oven temperature deal curve. Max. Temperature is 260°C;
- 2) Refer to IPC/JEDEC standard; Peak TEMP<260°C; Times: ≤2 times, suggest only do once reflow soldering on module surface in case of SMT double pad involved. Contact us if special crafts involved.

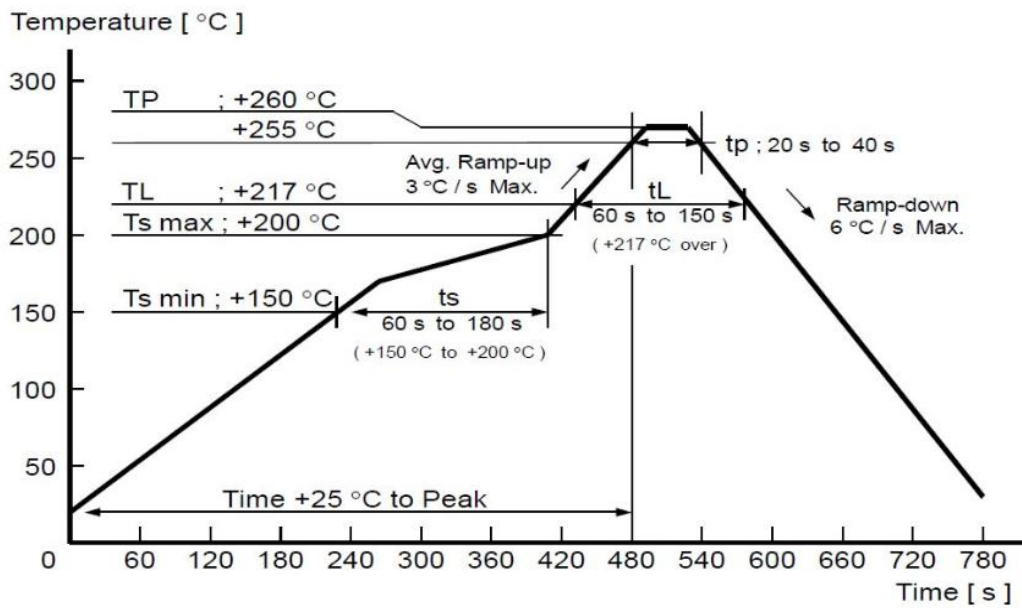

- 3)
- 4) Suggesting to make 0.2mm thickness of module SMT for partial ladder steel mesh, then make the opening extend 0.8mm
- 5) After unsealing, it cannot be used up at one time, should be vacuumed for storage, couldn't be exposed in the air for long time. Please avoid getting damp and soldering-pan oxidizing. If there are 7 to 30 days interval before using online SMT, suggest to bake at 65-70 °C for 24 hours without disassembling the tape.
- 6) Before using SMT, please adopt ESD protection measure.

11 Package Information

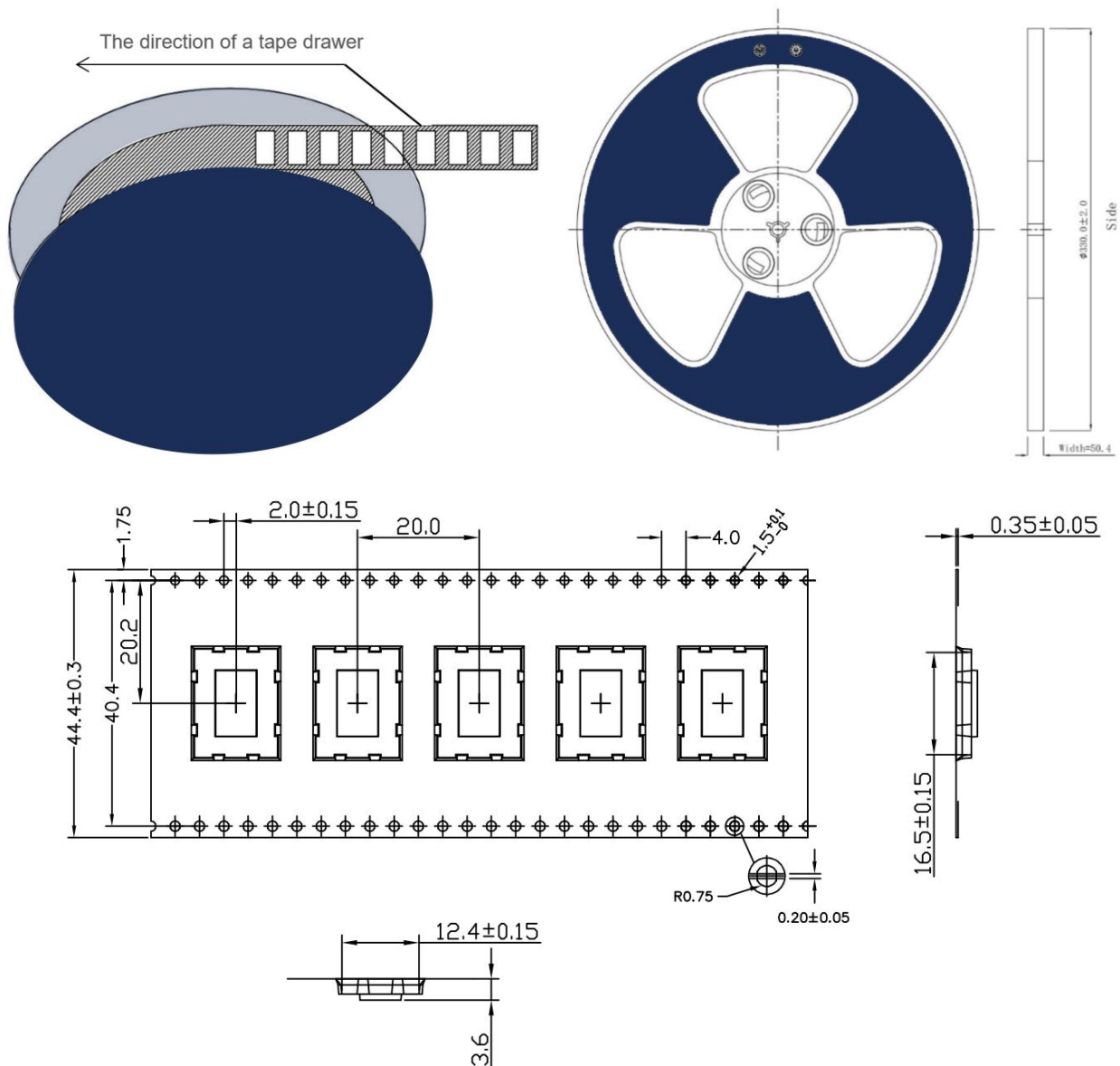

* (Default unit: mm Default tolerance: ± 0.1)

Packing detail	Specification	Net weight	Gross weight	Dimension
Quantity	850PCS	478g	1328g	W: 44mm,T:0.35mm

*** Note:** Default weight tolerance all are within 10g (except the special notes)

● Quality

The company has its own factory, advanced production equipment, and a refined quality management system. It has passed ISO9001 quality system certification, ISO14001 environmental management system certification, ISO27001 information security management system certification, OHSAS18001 occupational health and safety management system certification, and BSCI commercial and social standard certification. Each product has undergone emission power testing, sensitivity testing, power consumption testing, stability testing Strict testing such as aging testing. The fully automated modular production line has been officially put into use, with a production capacity of one million tons, meeting the needs of multi output production.

● Contact Us

Shenzhen Innovation Micro Technology Co., Ltd. always adheres to the corporate mission of "providing customers with high-quality connection modules quickly", providing you with the most timely and comprehensive services. If you need any help and support, please feel free to contact our relevant personnel or contact us as follows:

Web: www.minewsemi.com

Email: minewsemi@minew.com

Shop: <https://minewsemi.1688.com/>

Tel: +86 0755-28010353

Address: 3rd Floor,I Building, Gangzhilong Science Park, NO.6, Qinglong Road,Longhua District, Shenzhen, China

Click the icon to view and download the latest product documents electronically.



Related Documents: Chip Specification

● Copyright Statement

This manual and all the contents contained in it are owned by Shenzhen Minewsemi Co., Ltd. and are protected by Chinese laws and applicable international conventions related to copyright laws.

The certified trademarks included in this product and related documents have been licensed for use by MinewSemi. This includes but is not limited to certifications such as BQB, RoHS, REACH, CE, FCC, BQB, IC, SRRC, TELEC, WPC, RCM, WEEE, etc. The respective textual trademarks and logos belong to their respective owners. For example, the Bluetooth® textual trademark and logo are owned by Bluetooth SIG, Inc. Other trademarks and trade names are those of their respective owners. Due to the small size of the module product, the "®" symbol is omitted from the Bluetooth Primary Trademarks information in compliance with regulations.

The company has the right to change the content of this manual according to the technological development, and the revised version will not be notified otherwise. Without the written permission and authorization of the company, any individual, company, or organization shall not modify the contents of this manual or use part or all of the contents of this manual in other ways. Violators will be held accountable in accordance with the law.

MINEWSEMI

Tel: 0086-755-2801 0353

Email: minewsemi@minew.com

Web: www.minewsemi.com

Address: 3rd Floor, Building I, Gangzhilong Science Park, Qinglong Road, Longhua District, Shenzhen, 518109, China

