

GNSS Module ME31GR01

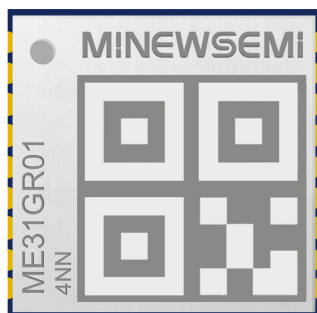

Datasheet
V 1.0.0



Version Note

Version	Details	Contributor(s)	Date	Notes
1.0.0	First edit	Michelle, Leo	2024.10.09	

Part Number

Model	Hardware Code
ME31GR01	4NN

Click the icon to view and download the latest product documents electronically.
https://en.minewsemi.com/file/ME31GR01_Datasheet_EN.pdf



INDEX

1 Product Introduction	04
1.1 General Description	04
1.2 Key Parameter	04
2 Technical Information	05
2.1 Supporting Constellations	05
2.2 Satellite-based Augmentation System (SBAS)	05
2.3 Quasi-Zenith Satellite (QZSS)	05
2.4 Satellite Enhancement Code Differential DGNSS	05
2.5 AGPS	06
2.6 Crystal Oscillators	06
2.7 Real Time Clock (RTC)	06
2.8 Power System	06
2.9 Working Mode	06
3 Electrical Specification	07
3.1 Absolute Maximum Rating	07
3.2 DC Characteristics	07
3.3 Power Wastage	07
3.4 Antenna Gain Requirements	08
4 Package Definition	08
4.1 Module Pin Definitions	08
4.2 Mechanical Dimensions	09
5 Reference Design	10
5.1 Schematic Design	10
5.2 LAYOUT Notes	11
5.3 Power Supply	11
5.4 Antennae	11
5.5 Serial Port Communication	11
5.6 Startup process	12
6 Software Protocol	12
6.1 NEMA0183 Pact	12
6.2 Example data	13
6.3 Example of an actual star search	14
6.4 Common Commands	14
7 Packaging and Protection	15
7.1 Wrap	15
7.2 Carrier Belts and Trays	15
7.3 Stockpile	16
7.4 ESD Protection	16
7.5 Production Requirements	16
8 Ordering Information	17
8.1 Ordering Model	17
9 Storage Conditions	17
10 Handling Conditions	17
11 Quality	18
12 Copyright Statement	18
13 Related Documents	18

1 PRODUCT INTRODUCTION

1.1 General Description

The ME31GR01 is a single-frequency, full-constellation GNSS module. Its multi-constellation RF front-end architecture enables simultaneous reception from all four major GNSS constellations (GPS, Beidou, Glonass, and Galileo), with support for QZSS and SBAS satellites. This provides the receiver with excellent sensitivity and acquisition capabilities. The module's superior interference suppression characteristics ensure reliable positioning even in challenging signal conditions. The multi-constellation combination significantly increases the number of visible satellites when navigating in dense urban canyons, reduces the time to first fix (TTFF), and improves positioning accuracy, enabling precise location tracking even in harsh environments.

The ME31GR01's outstanding positioning performance makes it an ideal choice for vehicle trackers, two-wheeler tracking, shared e-bike systems, T-Box, in-car navigation, transportation applications (such as industrial vehicles and fleet management), and inspection operations across both industrial and consumer sectors.

1.2 Key Parameters

ME31GR01 Parameters	
Operating Frequency	GPS/QZSS L1 C/A: 1575.42±1.023 MHz BDS B1I: 1561.098±2.046 MHz B1c: 1575.42±16.368 MHz GLONASS G1: 1598.063 -1605.375 MHz GALILEO E1: 1575.42±2.046 MHz QZSS L1 C/A: 1575.42±1.023 MHz SBAS L1 C/A: 1575.42±1.023 MHz
Sensitivity ¹	Cold start: -148dBm; Recapture: -159dBm; Track: -165dBm;
First Positioning Time ¹	Cold start: ≤28s; Hot start: 1s;
Positional Accuracy ²	open sky: <1.5 m CEP
Velocity Accuracy ²	<0.05 m/s
Time accuracy ²	20ns
operating temperature	Operating temperature: -40°C to +85°C
Refresh rate	Default GNSS: 1Hz, maximum 5Hz supported
Baud	Main Serial Port 115200bps (factory default)
RTCM differential output	RTCM3.x exports
Supported Protocols	NMEA 0183 protocols Ver. 4.0/4.1, RTCM 3.x

2 TECHNICAL INFORMATION

2.1 Supporting Constellations

The ME31GR01 can simultaneously receive L1-band satellite signals supporting GPS, BDS, GLONASS, GALILEO, QZSS, and Satellite Based Augmentation System SBAS (WAAS, EGNOS, GAGAN, MSAS) due to its multi-constellation RF front-end architecture.

2.2 Satellite-based Augmentation System (SBAS)

The ME31GR01 supports the reception of SBAS broadcast signals. These systems supplement GNSS data with other regional or wide-area GPS augmentation data. The system broadcasts distance correction and integrity information via satellite, which can be used by GNSS receivers to improve the accuracy of results. SBAS satellites can be used as add-on satellites for ranging (navigation) to further improve availability. The following SBAS types are supported: GAGAN, WAAS, EGNOS and MSAS.

Typology	Satellite Navigation System	Operation and Maintenance Country/region
Master Navigation System (GNSS)	GPS	United States of America
	Beidou (BDS)	China
	GLONASS	Georgia
	GALILEO	EU
local Navigation system	QZSS	Japanese
	NAVIC/IRNSS	India
Star-based Wide Area Strengthening (SBAS)	WASS	United States of America
	EGNOS	EU
	MSAS	Japanese
	GAGAN	India

2.3 Quasi-Zenith Satellite (QZSS)

The Quasi-Zenith Satellite System (QZSS) is a navigation satellite overlay system for the Pacific Ocean covering Japan and Australia that transmits other GPS L1C/A signals. The module is capable of receiving and tracking these signals simultaneously with GPS, which improves availability and maintains positioning especially in poor signal conditions such as urban canyons.

2.4 Satellite Enhancement Code Differential DGNSS

The ME31GR01 supports the use of the code difference function, D-GNSS, with access to pseudo-range correction information in RTCM 2.3 or user-defined formats. The ME31GR01, used as a mobile station, will attempt to provide the best possible positioning accuracy depending on the correction data received. Upon receipt of the RTCM message input stream, it will immediately enter differential mode. Upon entering D-GNSS mode, an improvement in positioning accuracy can be expected. D-GNSS is a differential system where the mobile station uses reference data from a reference station. If the RTCM correction function is not available, it will operate as a stand-alone precision receiver for GNSS star-based or single-point positioning.

2.5 AGPS

The ME31GR01 supports for the AGPS Accelerated Positioning Scheme. Please refer to "AGPS Integration Guide.pdf" for specific usage methods.

2.6 Crystal Oscillators

The ME31GR01 uses TCXO to allow weak signal acquisition, resulting in faster start-up and re-acquisition times. TCXO allows the product to ensure that it is stable and immune to frequency interference over its entire operating range (-40°to + 85°C), making it a positioning module with reliable positioning.

2.7 Real Time Clock (RTC)

The RTC is driven by a 32 kHz oscillator using an RTC crystal. If the mains voltage fails, some parts of the receiver will shut down, but the RTC will still operate to provide a timing reference for the receiver. This mode of operation is called "hardware backup mode" and allows all relevant data to be saved in backup RAM for later hot-booting.

2.8 Power System

The ME31GR01 module is available in full operating mode and battery backup mode.

Full operation mode: All power supplies are normally supplied and the module is in full operation mode for normal signal reception and interpretation.

Battery Backup Mode: The module requires very little current (~40uA) to maintain the RTC clock and backup RAM.

2.9 Working Mode

The ME31GR01 supports two power consumption modes, Sleep mode and Active mode. It is possible to switch from Active mode to Sleep mode through software and hardware.

Active mode: Normal operation mode where the DSP core is active and all peripherals are available.

Sleep mode: In this mode, the Soc DSP core, all digital logic (except the RTC Always-On logic), and major portions of the analog/RF circuits are stopped and powered down so that total current can be minimized. In this mode, only GPIOs (serial ports) or RTC timers can wake up the system to Active mode.

In Sleep mode, the BeiDou reference time will run in the RTC timer. The ephemeris and other BeiDou data will be saved to flash periodically for fast startup. If AGNSS/AGPS is available, the time and ephemeris will be downloaded to the Soc chip, so there is no need to switch to Sleep mode if AGNSS/AGPS is available or if you don't care about the hot start TTFB, just don't provide the backup power supply and turn off the VCC main power supply when you don't need to use the positioning function.

ME32GR01 in software mode, when the module receives the host hibernation command and switches from Active mode to Sleep mode, the system shall keep power supply state. After entering Sleep mode, the VCC main power can be further turned off to save power, but at this time, it is necessary to ensure that V_BACKUP is in the power supply state.

In hardware mode, if the module is in Active mode, VCC is powered off and V_BACKUP remains active high, ME32GR01 will automatically switch to Sleep mode. When the module is in sleep mode, all IOs connected to the module should remain in a low or high impedance state. If any of the connected IO pins present are in a high state, the leakage of the ME32GR01 sleep circuitry will increase. When the ME32GR01 wakes up from sleep mode (triggered by an RTC timer or GPIO), the VCC main power supply must remain active.

3 ELECTRICAL SPECIFICATION

3.1 Absolute Maximum Rating

Notation	Parameters	Minimum Value	Maximum Value	Unit
VCC	Mains voltage	-0.5	3.63	V
VBAT	Backup power supply voltage	-0.5	3.63	V
VI-max	I/O Pin Input Voltage	-0.5	3.63	V
Vhbm	ESD Contact	-	2000	V
T-storage	Storage temperature	-40	+85	°C
T-solder	Reflow temperature	--	250	°C

Pressurizing the equipment beyond the "Absolute Maximum Rating" may cause permanent damage. The above figures are pressure ratings only. Products are not overvoltage or reverse voltage protected. If necessary, voltage spikes exceeding the supply voltage specifications listed in the table above must be limited to the specified range using an appropriate protection diode.

3.2 DC Characteristics

Notation	Parameters	Minimum Value	Typical Value	Maximum Value	Unit
VCC	Mains voltage	2.0	3.3	3.6	V
VBAT	Backup power supply voltage	2.5	3.3	3.6	V
IABCmax	ANT_BIAS Maximum operating current	--	3.3	45	mA
Tenv	Operating temperature	-40	--	85	°C

3.3 Power Wastage

Notation	Parameters	Measurement Pins	Typical Value	Unit
ICCRX1 ^[1]	capture phase	VCC ^[2]	18	mA
ICCRX2 ^[1]	tracking stage	VCC ^[2]	16	mA
ICCDBM	hibernation	VBAT ^[3]	22	uA



Remarks:
 * [1] Under open sky, GNSS, L1 band, tracking 32 satellites, successful positioning
 * [2] Condition: VCC=3.3V, room temperature, all pins dangling
 * [3] Condition: VBAT=3.3V, room temperature, all pins dangling

All of the above specifications are at 25°C ambient temperature. Extreme operating temperatures can seriously affect specification values. Applications operating near temperature limits.

The values in the table are for customer reference only and are intended as examples of typical power requirements. Values are characterized as samples and actual power requirements will vary depending on the firmware version used, external circuitry, number of satellites tracked, signal strength, type of activation as well as time, duration, and test conditions.

The measured values of the capture phase current are as follows:

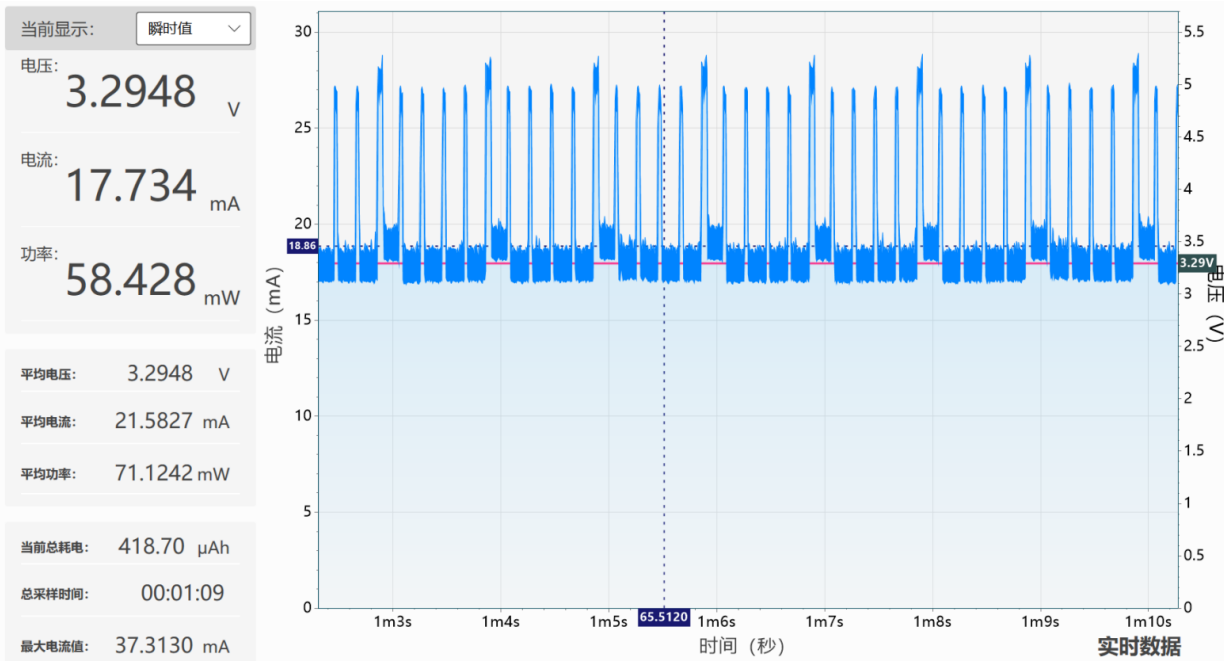

3.4 Antenna Gain Requirements

Since the ME31GR01 has built-in LNA to support passive GNSS antennas, external active antenna gain is noted to be controlled.

Notation	Parameters	Min	Max	Unit
RFgain	Input Gain	0	30	dB

4 PACKAGE DEFINITION

4.1 Module Pin Definitions

The ME31GR01 is available in the industry's most common 10*10mm, LCC-18pin package, defined as follows:

10	GND	RESET	9
11	RF_IN	VCC	8
12	GND	NC	7
13	NC	ME31GR01 V_BCKP	6
14	VCC_RF	NC	5
15	NC	PPS	4
16	NC	RXD	3
17	NC	TXD	2
18	NC	GND	1

TOP VIEW



Functionality	Name	Number	Signal Type	Description
power supply	VCC	8	Power	Mains Power-Input. Ensure that the power input is clean and stable.
	V_BCKP	6	Power	Backup Power Input. It is recommended to connect the backup power supply voltage to this pin in order to position the module for hot and warm start functions. If no backup power is available, V_BCKP can be connected to the main power supply or left dangling.
	GND	1,10,12	GND	Ensure that all GND pins on the module are well grounded.
Antennae	RF_IN	11	I	Antenna input, impedance 50Ω
	VCC_RF	14	O	External active antenna power supply output 3.3V
serial port /IO	TXD	2	O	UART output, TTL level, GNSS_TX
	RXD	3	I	UART input, TTL level, GNSS_RX
	PPS	4	O	Seconds pulse signal. 3.3V level. Suspend if not used.
	RESET	9	I	Reset signal, reset low. Suspension is recommended.
Else	NC	5,7,13~18	-	NC, no definition, please hover

4.2 Mechanical Dimensions

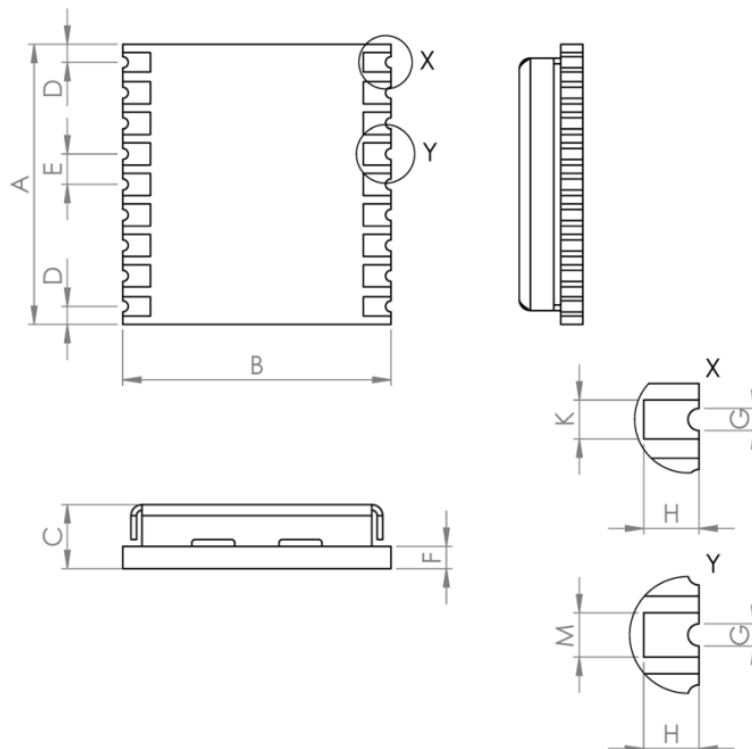

Serial Number	Minimum (mm)	Typical Values (mm)	Maximum Value (mm)
A	10.4	10.5	10.8
B	9.5	9.7	9.9
C	1.9	2.0	2.2
D	0.55	0.8	0.95
E	1.0	1.1	1.2
F	0.5	0.6	0.7
G	0.4	0.5	0.6
H	0.7	0.8	0.9
K	0.7	0.8	0.9
M	0.8	0.9	1.0

5 REFERENCE DESIGN

5.1 Schematic Design

The reference design of ME31GR01 is shown below. When connecting the active antenna, please make sure that the 47nH inductor at L2 position is in the SMD state, which is used to power the active antenna, and the characteristic impedance from RF_IN pin to the antenna connector is 50Ω. When applying the antenna, the performance of the antenna is crucial to the system, and it is important to ensure the technical parameter of the dual-band high-precision antenna. Pin6 can be connected to the V_BCKP backup power supply, which supports the hardware hot-start.

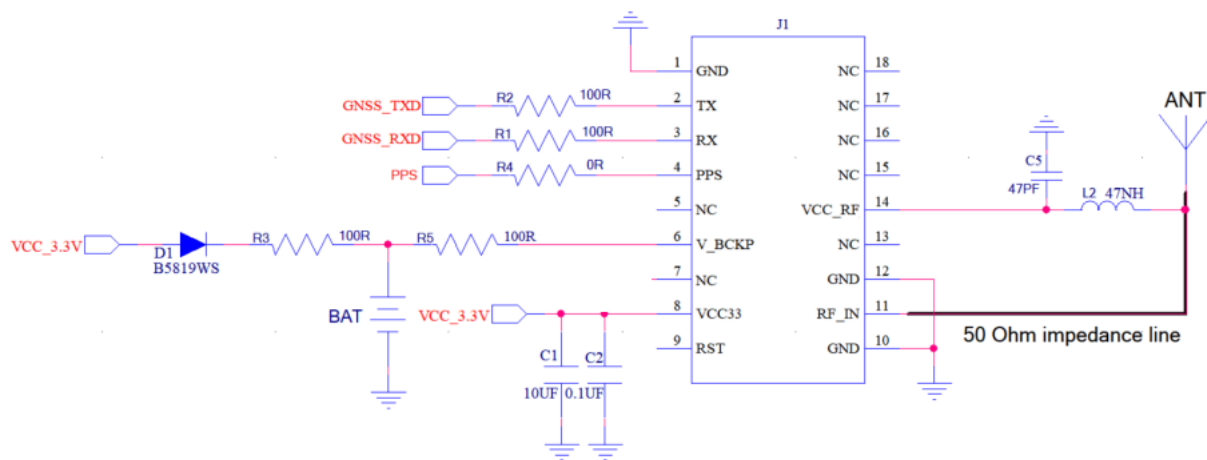

5.2 LAYOUT Notes

- (1) Decoupling capacitors are placed close to the module power supply pins, and ensure that the power supply alignment width is more than 0.5mm;
- (2) No wires are allowed to be routed at the bottom of the module patch;
- (3) The RF alignment between the RF port of the module and the antenna interface should be at least 0.2mm~0.3mm, and the coplanar waveguide impedance model should be adopted, and the spacing between the alignment and the ground copper skin should be controlled to be about 1 times of the spacing, and the impedance should be guaranteed to be 50Ω;
- (4) The alignment from the module RF port to the antenna connector references Layer 2 ground and ensures that the Layer 2 ground plane is relatively complete;
- (5) Modules should not be placed near sources of interference, such as communication module antennas, RF alignments, crystal oscillators, large inductors, and high-frequency digital signal lines.

5.3 Power Supply

The ME31GR01 Positioning Module is equipped with two power supply pins: VCC and V_BACKUP. the main power supply is fed to the module via the VCC pin, and the backup power supply is fed to the module via the V_BACKUP pin. To ensure the positioning performance of the module, the ripple of the module power supply should be controlled as much as possible. It is recommended to use an LDO supply with a maximum output current greater than 100mA. If the module's main power supply is disconnected, the system will provide power to the RTC and the Battery Backup RAM (BBR) through V_BACKUP.

Therefore, even if the main power supply is disconnected, the ephemeris data can still be retained with the backup power supply and can be used for a hot or warm start when the system is powered up again. If no backup power supply is connected and no data is received by the module, then the system will perform a cold start when it is powered up again. Note: If there is no backup power available, connect the V_BACKUP pin to the VCC mains or leave it idle.

5.4 Antenna

The ME31GR01 has a built-in low noise figure LNA and SAW. it is recommended to use an active antenna with a gain of less than 25dB and a noise figure of less than 1.5dB. The module supplies power to the external active antenna via RF_IN. If the active antenna cable is long, an active antenna with at least 15dB of gain is required to compensate for line losses. To maintain ground integrity, it is recommended that no or as few wires as possible be routed under the module.

5.5 Serial Port Communication

Provide one way TTL level universal asynchronous transceiver (UART), the data format is: 1 bit start bit, 8 bit data bit, 1 bit stop bit, no parity bit, the default baud rate is 115200bps. after the module is normally powered on, the serial port will automatically send NMEA data. The host computer can set the module working mode and baud rate through the serial port. When this module is used in some specific application scenarios, the main power of the module may be turned off due to the power saving strategy, so as to further reduce the power consumption.

In this case, in order to avoid the high level of the serial port affecting the normal operation of the module, it is strongly recommended to disconnect the serial port connection at the same time when disconnecting the main power supply, or set the serial port to the state of input state + pull-down resistor or high resistance state + pull-down resistor.

5.6 Startup Process

The module startup process is as follows:

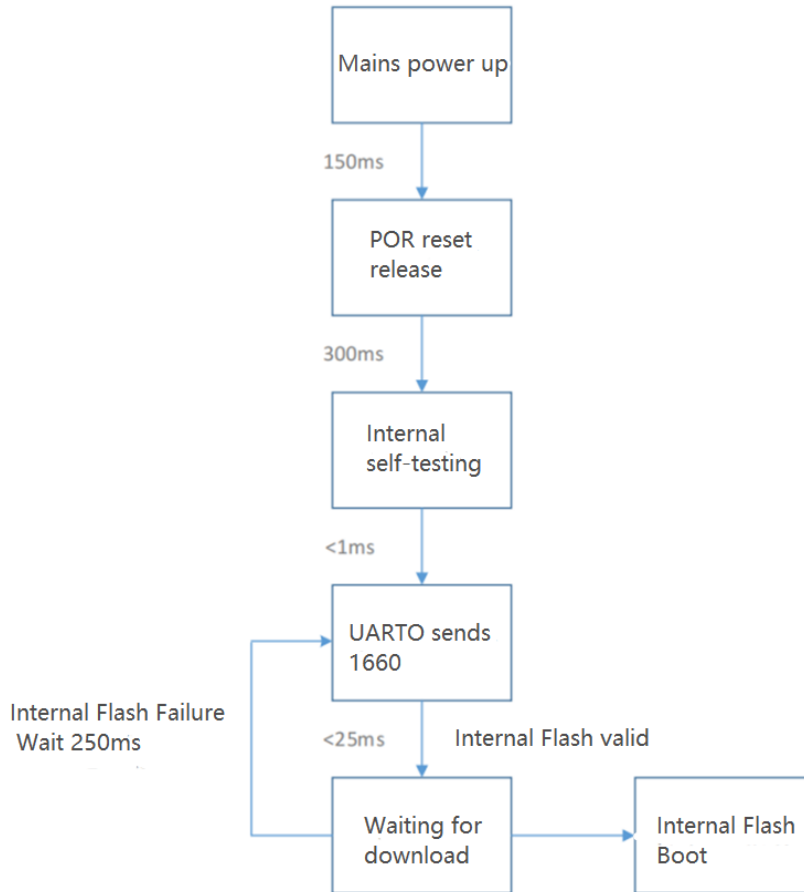

6 SOFTWARE PROTOCOL

6.1 NEMA0183 Pact

The NMEA protocol is an ASCII based protocol where the record starts with a \$ and ends with a carriage return/line feed character, and the checksum of the NMEA message, which can be used to detect corrupted data transmission. The frame structure is as follows:

Start Character	Checksum Range			Checksum	End Flag
\$	Talker ID	Message ID	[,field 0]...[,field N]	*Checksum	<CR><LF>

The NEMA message output for the ME31GR01 is shown in the following table:

NMEA Record	Description	Default
GNNGGA	Global positioning system fixed data	Y
GNGLL	Geographic position—latitude/longitude	Y
GNNSA	GNSS DOP and active satellites	Y
GNPGSV	GNSS satellites in view for GPS	Y
GNLGSV	GNSS satellites in view for GLONASS	Y
GNBDGSV	GNSS satellites in view for BD	Y
GNAGSV	GNSS satellites in view for Galileo	Y
GNRMC	Recommended minimum specific GNSS data	Y
GNVTG	Course over ground and ground speed	Y
GNZDA	Date and Time	N
GNGST	Position error statistics	Y
GNHDT		

6.2 Example data

Serial port data within 1 second of the example after positioning:

```

$GNNGGA,065826.00,2242.2940466,N,11401.6896089,E,1,31,0.5,133.811,M,0.000,M,,*4B
$GNNSA,A,3,02,04,07,08,09,16,21,30,194,195,196,199,1.0,0.5,0.8,1*34
$GNNSA,A,3,,,,,,,,,1.0,0.5,0.8,1*3D
$GNNSA,A,3,01,02,03,04,06,07,09,10,12,16,24,26,1.0,0.5,0.8,4*33
$GNNSA,A,3,29,35,59,60,,,,,,,,,1.0,0.5,0.8,4*3F
$GNNSA,A,3,,,,,,,,,1.0,0.5,0.8,2*3E
$GNNSA,A,3,02,08,15,,,,,,,,,1.0,0.5,0.8,3*31
$GNPGSV,5,1,17,01,00,000,40,02,55,156,45,04,20,195,37,07,49,321,42,1*61
$GNPGSV,5,2,17,08,56,010,43,09,29,237,40,16,17,077,37,21,61,126,45,1*6D
$GNPGSV,5,3,17,27,00,000,38,30,18,320,34,194,56,056,42,195,60,101,43,1*60
$GNPGSV,5,4,17,196,21,165,39,199,60,149,37,43,00,000,43,56,00,000,45,1*6B
$GNPGSV,5,5,17,57,00,000,41,,,,,,,,,1*55
$GNBDGSV,6,1,21,01,46,125,43,02,46,234,39,03,61,189,43,04,32,111,39,1*71
$GNBDGSV,6,2,21,06,72,187,43,07,62,319,41,09,79,264,42,10,56,298,40,1*71
$GNBDGSV,6,3,21,12,26,215,39,16,70,184,45,24,17,318,37,26,61,353,45,1*7D
$GNBDGSV,6,4,21,29,19,038,40,35,80,037,47,38,00,000,37,39,00,000,45,1*75
$GNBDGSV,6,5,21,40,00,000,43,44,00,000,46,45,00,000,46,59,49,131,45,1*74
$GNBDGSV,6,6,21,60,42,238,43,,,,,,,,,1*48
$GNBDGSV,3,1,09,24,17,318,34,26,61,353,41,29,19,038,34,35,80,037,43,2*71
$GNBDGSV,3,2,09,38,00,000,35,39,00,000,42,40,00,000,40,44,00,000,42,2*79
$GNBDGSV,3,3,09,45,00,000,42,,,,,,,,,2*48
$GNAGSV,1,1,03,02,33,066,39,08,24,204,37,15,36,176,39,,,,,7*4F
$GNVTG,0.00,T,,M,0.00,N,0.00,K,A*23
$GNRMC,065826.00,A,2242.2940466,N,11401.6896089,E,0.00,0.00,300124,,,A,V*39
$GNGST,065826.00,,,,,0.93,0.74,1.65*7D
$GNGLL,2242.2940466,N,11401.6896089,E,065826.00,A,A*70
    
```

6.3 Example of an actual star search



6.4 Common Commands

CMD TYPE	CMD Example:
Hot start	\$POLCFGRESET,0
Cold start	\$POLCFGRESET,1
Baud rate 115200	\$POLCFGPRT,115200,0
Baud rate 9600 (too many satellites may congest the serial port)	\$POLCFGPRT,9600,0
Turn off GSV output	\$POLCFGMSG,0,2,0
Turn off GSA output	\$POLCFGMSG,0,1,0
Turn off GLL output	\$POLCFGMSG,0,13,0
Turn off GST output	\$POLCFGMSG,0,12,0
Turn off VTG output	\$POLCFGMSG,0,3,0
Sleep mode (can be woken up after receiving any data on the serial port)	Hex directives: 42 4b 51 05 00 03 00 08 00 00 00 00 00 00 00



Remarks:

1. All text format control commands should add Carriage Return (CR) and Line Feed (CF);
2. All software configurations will be invalidated after charging and powering up the main power supply VCC of the module, and need to be initialized again after powering up the module if necessary;
3. Data configurations can be validated after powering up the module due to the built-in Flash memory unit in the ME31GR01; a higher baud rate may be necessary for high refresh rates, e.g., 115200 or higher to avoid serial port data congestion.

7 PACKAGING AND PROTECTION

7.1 Wrap

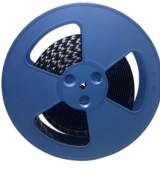
The ME31GR01 is humidity and static sensitive. During packaging and transportation of the product, be sure to follow the handling requirements and take appropriate precautions to minimize product damage. The following table shows the standard packaging structure for transportation of the product.

Offerings	Reels	Sealed Bags	Shipping Cartons
			
ME31GR01	1000pcs/roll	1 roll/bag	1 bag/box, 3 boxes/ctn

7.2 Carrier Belts and Trays

The ME32GR01 is supplied on a reel (consisting of a tape and reel) and packaged in a ziplock bag with an anti-static effect to meet the customer's needs for efficient production, batch installation and removal. The following picture shows the dimensional details of the tape reel.

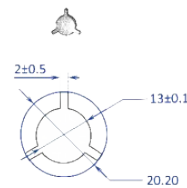
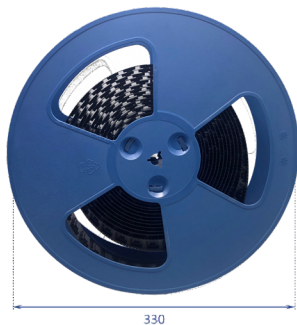
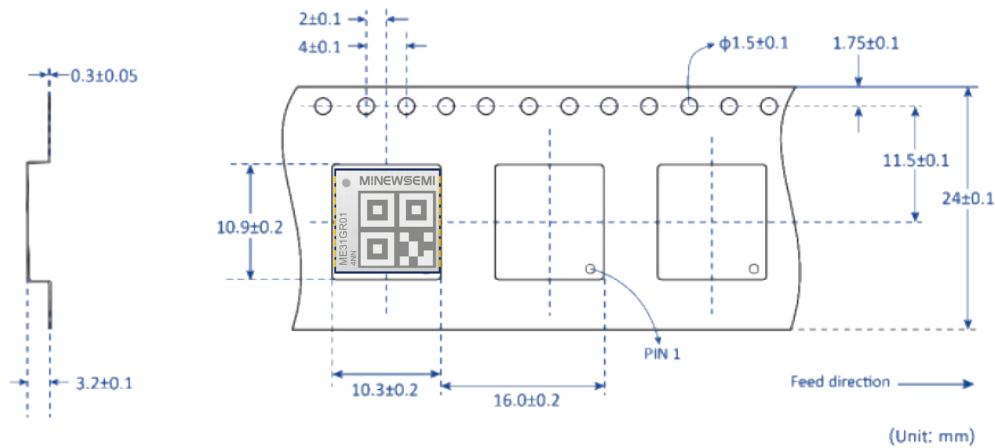

(Unit: mm)



7.3 Stockpile

In order to prevent the product from moisture and electrostatic discharge, the sealed bag of the product is equipped with desiccant and humidity indicator card, which allows the user to know the humidity condition of the environment in which the product is located. The product has a moisture sensitivity rating of MSL3.

7.4 ESD Protection

The GNSS positioning module contains highly sensitive electronics and is an electrostatic sensitive device (ESD). Please note the following precautions, as failure to follow these precautions may result in serious damage to the module!

Ground yourself before patching the antenna. Do not touch any charged capacitors and other devices (e.g., antenna patch ~10 pF; coaxial cable ~50 -80 pF/m; soldering iron) when bringing out the RF pin;

To prevent electrostatic discharge, do not expose the antenna area; if exposed by design, take appropriate ESD precautions and do not touch any exposed antenna area;

Be sure to use an ESD safe soldering iron when soldering RF connectors and antenna patches.

Add ESD diode to RF input to prevent ESD; add ESD diode to UART interface.



7.5 Production Requirements

The recommended welding temperature profile is shown below:

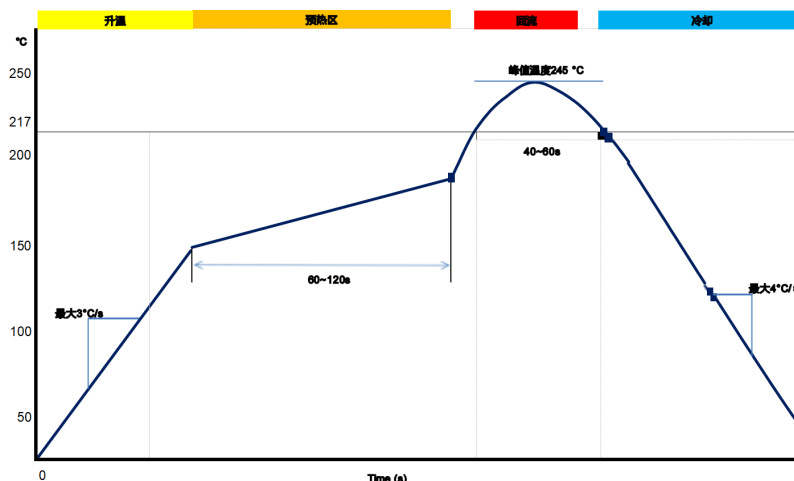

In order to prevent the module from falling off during soldering, please do not design the module to be soldered on the back of the board, and it is better not to go through two soldering cycles.

The setting of soldering temperature depends on many factors in the product factory, such as the nature of the motherboard, paste type, paste thickness, etc. Please also refer to the relevant IPC standards and paste specifications.

Due to the relatively low temperature of leaded soldering, please prioritize other components on the board if using this soldering method. The openings of the stencil should meet the customer's own product design requirements and inspection specifications, and the thickness of the stencil is recommended to be 0.15mm.

8 ORDERING INFORMATION

8.1 Ordering Model

Ordering Model	Product Name	Default Baud Rate	Feature	Default Satellite Reception Frequency	Physical Interface
ME31GR01	Single-frequency full-system satellite positioning module	115200	single-frequency full constellation	GPS/BDS/GLO/GAL/QZSS, Support B1C	10*10, LCC18

9 STORAGE CONDITIONS

- Please use this product within 6 months after signing up for it.
 - This product should be stored without opening the package at an ambient temperature of 5~35°C and a humidity of 20~70%RH.
 - This product will be stored for more than 6 months after receipt. They must be confirmed before use.
 - Products must be stored in non-corrosive gases (Cl₂, NH₃, SO₂, NO_x, etc.).
 - To avoid damage to the packaging materials, no excessive mechanical impact shall be applied, including but not limited to sharp objects adhering to the packaging materials and products falling.
- This product is suitable for MSL3 (based on JEDEC standard J-STD-020).
 - After opening the package, the product must be stored under conditions of ≤30°C/<60%RH. It is recommended to use it within 168 hours after opening the package.
 - When the color of the indicator in the package changes, the product should be baked before welding.
- When exposed to (≥168h@30°C/60%RH) conditions, the recommended baking conditions:
 1. 120 +5/-5°C, 8 hours, 1 time
Products must be baked individually on heat-resistant trays because the materials (base tape, roll tape and cover tape) are not heat-resistant and the packaging materials may deform when the temperature is 120°C;
 2. 90°C +8/-0°C, 24 hours, once
The base tape can be baked together with the product at this temperature, Please pay attention to even heating.

10 HANDLING CONDITIONS

- Be careful in handling or transporting products because excessive stress or mechanical shock may break products.
- Handle with care if products may have cracks or damages on their terminals. If there is any such damage, the characteristics of products may change. Do not touch products with bare hands that may result in poor solder ability and destroy by static electrical charge.

11 QUALITY

Cognizant of our commitment to quality, we operate our own factory equipped with state-of-the-art production facilities and a meticulous quality management system. We hold certifications for ISO9001, ISO14001, ISO27001, OHSAS18001, BSCI.

Every product undergoes stringent testing, including transmit power, sensitivity, power consumption, stability, and aging tests. Our fully automated module production line is now in full operation, boasting a production capacity in the millions, capable of meeting high-volume production demands.

12 COPYRIGHT STATEMENT

This manual and all the contents contained in it are owned by Shenzhen Minewsemi Co., Ltd. and are protected by Chinese laws and applicable international conventions related to copyright laws.

The certified trademarks included in this product and related documents have been licensed for use by MinewSemi. This includes but is not limited to certifications such as BQB, RoHS, REACH, CE, FCC, BQB, IC, SRRC, TELEC, WPC, RCM, WEEE, etc. The respective textual trademarks and logos belong to their respective owners. For example, the Bluetooth® textual trademark and logo are owned by Bluetooth SIG, Inc. Other trademarks and trade names are those of their respective owners. Due to the small size of the module product, the "®" symbol is omitted from the Bluetooth Primary Trademarks information in compliance with regulations.

The company has the right to change the content of this manual according to the technological development, and the revised version will not be notified otherwise. Without the written permission and authorization of the company, any individual, company, or organization shall not modify the contents of this manual or use part or all of the contents of this manual in other ways. Violators will be held accountable in accordance with the law.

13 RELATED DOCUMENTS

- [MinewSemi_Product_Naming_Reference_Manual_V1.0](https://en.minewsemi.com/file/MinewSemi_Product_Naming_Reference_Manual_V1.0)
https://en.minewsemi.com/file/MinewSemi_Product_Naming_Reference_Manual_EN.pdf
- [MinewSemi_Connectivity_Module_Catalogue_V2.0](https://en.minewsemi.com/file/MinewSemi_Connectivity_Module_Catalogue_V2.0)
https://en.minewsemi.com/file/MinewSemi_Connectivity_Module_Catalogue_EN.pdf



For product change notifications and regular updates of Minewsemi documentation, please register on our website: www.minewsemi.com

MINEWSEMI



SHENZHEN MINEWSEMI CO., LTD.

-  0086-755-2801 0353
-  <https://minewsemi.com>
-  minewsemi@minew.com
-  <https://store.minewsemi.com>
-  No.8, Qinglong Road, Longhua District, Shenzhen, China